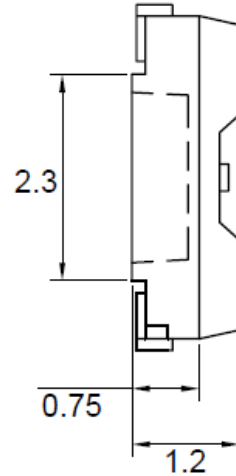
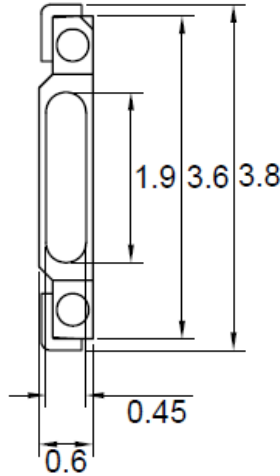
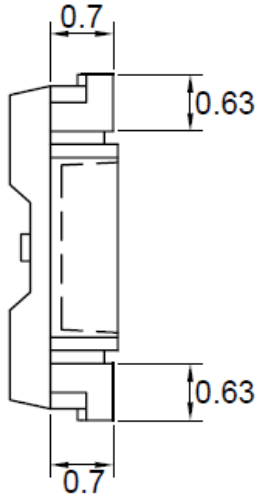
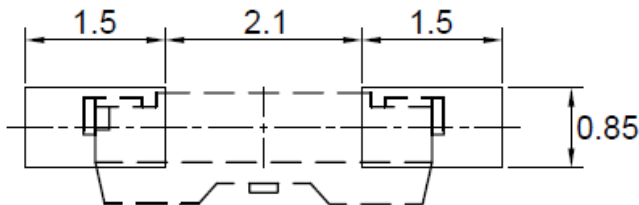

SPECIFICATION **CSPR155A2C**
PACKAGE OUTLINES

Cathode

Anode
Polarity
RECOMMEND PAD LAYOUT

Notes:

1. All dimensions are in millimeters (inches).
2. Tolerance is $\pm 0.25\text{mm}$ (0.01") unless otherwise noted.
3. Specifications are subject to change without notice.

Part Number	Chip Material	Color of Emission	Lens Type	Viewing Angle
CSPR155A2C	InGaAlP	Orange	Water Clear	120°



ChromeLED Corp. reserves the right to make changes at any time in order to supply the best product possible. The most current version of this document will always be available at: www.chromeled.com

ABSOLUTE MAXIMUM RATINGS
(TA=25°C)

Parameter	Symbol	Max Rating	Unit
Forward Current	I _F	50	mA
Reverse Current @ 5V	I _R	10	μA
Power Dissipation	P _d	120	mW
Operating Temperature Range	T _{OP}	-20~+80	°C
Storage Temperature Range	T _{STG}	-30~+100	°C
Peak Pulsing Current (1/10 duty f = 10KHz)	I _{FP}	90	mA
Soldering Temperature	T _{SOL}	Max 260°C for 5 sec Max	

OPTICAL-ELECTRICAL CHARACTERISTICS
(TA=25°C)

Parameter	Symbol	Test Condition	Value			Unit
			Min	Typ	Max	
Luminous Intensity	I _v	I _F = 20mA	200	320	-	mcd
Forward Voltage	V _F	I _F = 20mA	-	2.1	2.6	V
Reverse Leakage Current	I _R	V _R = 5V	-	-	10	μA
Viewing Angle at 50% I _v	2θ _{1/2}	I _F = 20mA	-	120	-	Deg
Peak Wavelength	λ _P	I _F = 20mA	-	610	-	nm
Dominant Wavelength	λ _D	I _F = 20mA	-	605	-	nm

*Tolerance of viewing angle: -10 / +5 deg.



ChromeLED Corp. reserves the right to make changes at any time in order to supply the best product possible. The most current version of this document will always be available at: www.chromeled.com

OPTICAL CHARACTERISTIC CURVES

TYPICAL ELECTRO-OPTICAL CHARACTERISTIC CURVES

Fig.1 Forward current vs. Forward Voltage

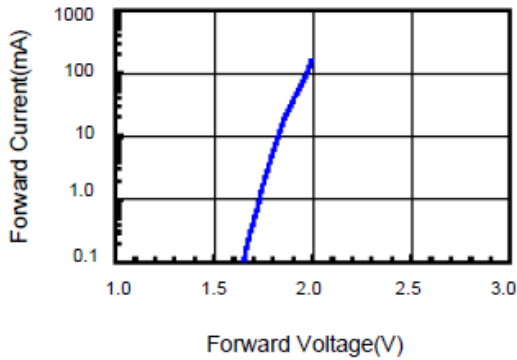

Fig.2 Relative Intensity vs. Forward Current

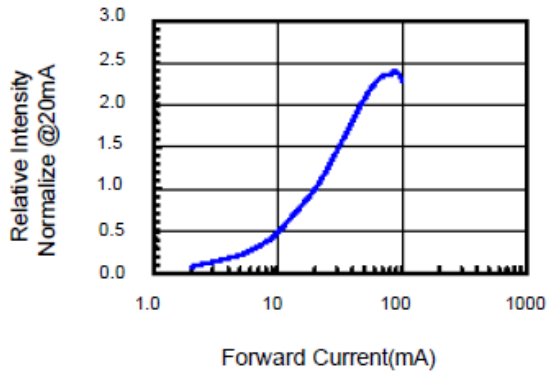

Fig.3 Forward Voltage vs. Temperature

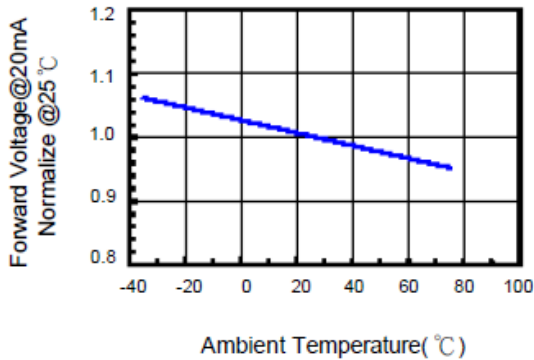

Fig.4 Relative Intensity vs. Temperature

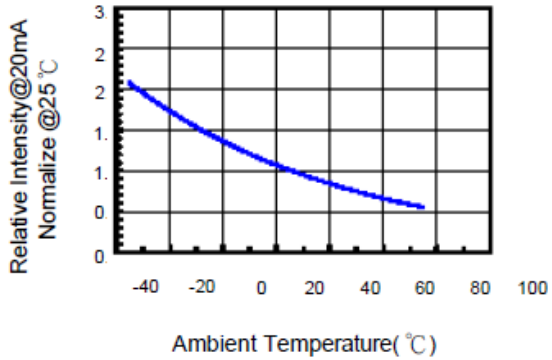

Fig.5 Relative Intensity vs. Wavelength

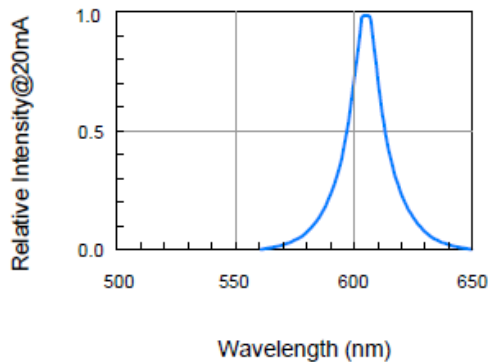
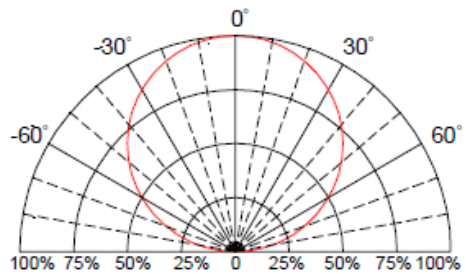

Fig.6 Directive Radiation



ChromeLED Corp. reserves the right to make changes at any time in order to supply the best product possible. The most current version of this document will always be available at: www.chromeled.com

PACKAGING SPECIFICATION

CARRIER TAPE DIMENSION

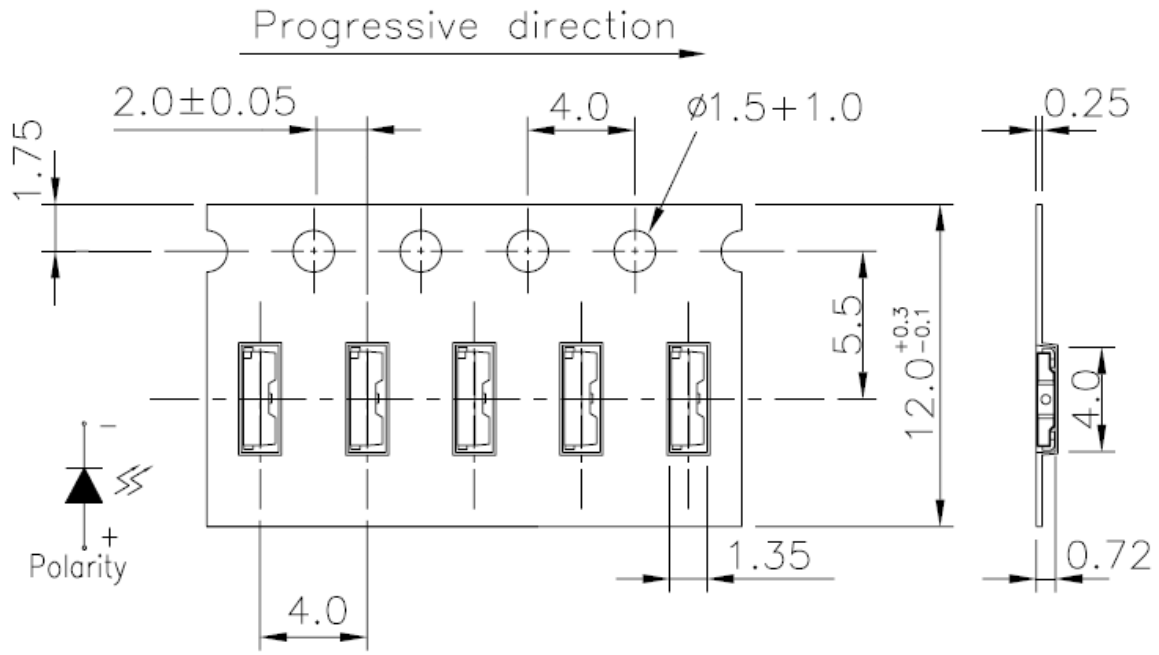

Note: The tolerances unless mentioned are ± 0.1 mm, Angle ± 0.5 ; Unit=mm

REEL DIMENSIONS

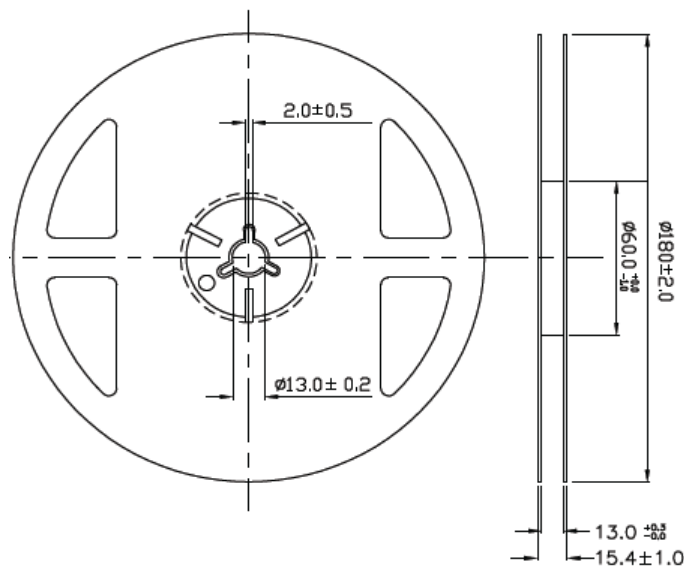

- Notes:
1. 250/500/1000/2000 pieces per reel
 2. Tolerance unless mentioned is ± 0.1 mm; Unit=mm



ChromeLED Corp. reserves the right to make changes at any time in order to supply the best product possible. The most current version of this document will always be available at: www.chromeled.com

SOLDERING CONDITIONS

RECOMMENDED Sn-PB IR-Reflow Soldering Profile



RECOMMENDED Pb-Free Soldering Profile



ChromeLED Corp. reserves the right to make changes at any time in order to supply the best product possible. The most current version of this document will always be available at: www.chromeled.com