

SPECIFICATION **CSP128CW2C**
PACKAGE OUTLINES

- Notes:
1. All dimensions are in millimeters (inches).
 2. Tolerance is $\pm 0.25\text{mm}$ (0.01") unless otherwise noted.
 3. Specifications are subject to change without notice.

Part Number	Chip Material	Color of Emission	Lens Type	Viewing Angle
CSP128CW2C	InGaN	White	Yellow Diffused	120°

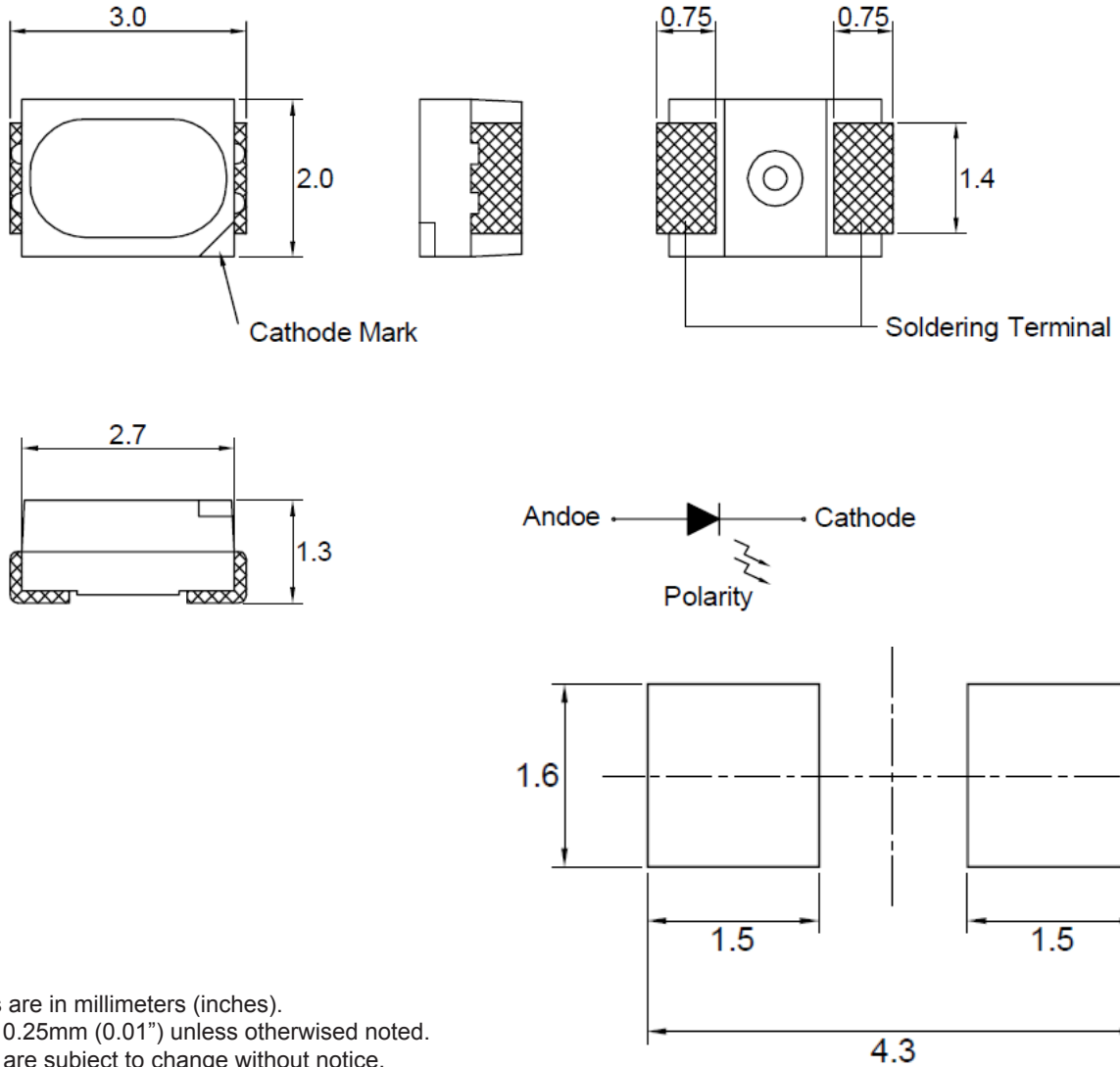

ChromeLED Corp. reserves the right to make changes at any time in order to supply the best product possible. The most current version of this document will always be available at: www.chromeled.com

ABSOLUTE MAXIMUM RATINGS
(TA=25°C)

Parameter	Symbol	Max Rating	Unit
Forward Current	IF	30	mA
Reverse Current @ 5V	IR	50	μA
Operating Temperature Range	TOP	-20~+80	°C
Storage Temperature Range	TSTG	-30~+100	°C
Peak Pulsing Current (1/8 duty f = 10KHz)	IFP	100	mA
Soldering Temperature	TSOL	Max 260°C for 5 sec Max	

OPTICAL-ELECTRICAL CHARACTERISTICS
(TA=25°C)

Parameter	Symbol	Test Condition	Value			Unit
			Min	Typ	Max	
Luminous Intensity	Iv	IF = 20mA	2300	2500	-	Mcd
Forward Voltage	VF	IF = 20mA	-	3.4	4.0	V
Reverse Leakage Current	IR	VR = 5V	-	-	10	μA
Viewing Angle at 50% Iv	2θ1/2	IF = 20mA	-	120	-	Deg
CIE Coordinates	X	IF = 20mA	0.31	-	0.35	-
	Y		0.32	-	0.37	-

*Tolerance of viewing angle: -10 / +5 deg.



ChromeLED Corp. reserves the right to make changes at any time in order to supply the best product possible. The most current version of this document will always be available at: www.chromeled.com

OPTICAL CHARACTERISTIC CURVES

Fig.1 Forward current vs. Forward Voltage

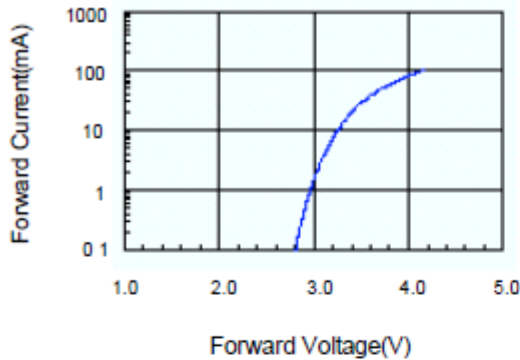

Fig.2 Relative Intensity vs. Forward Current

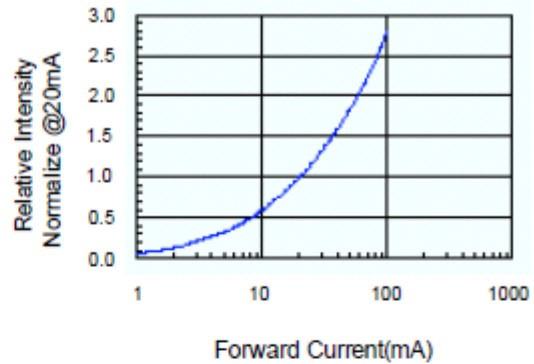

Fig.3 Forward Voltage vs. Temperature

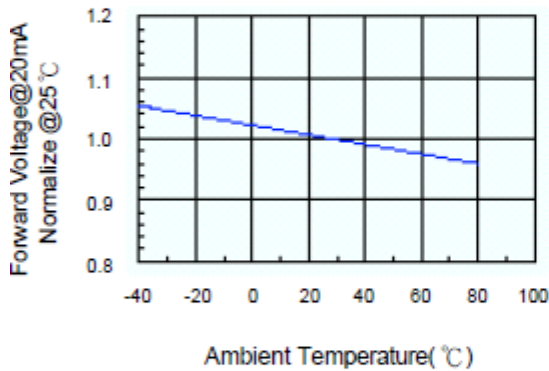

Fig.4 Relative Intensity vs. Temperature

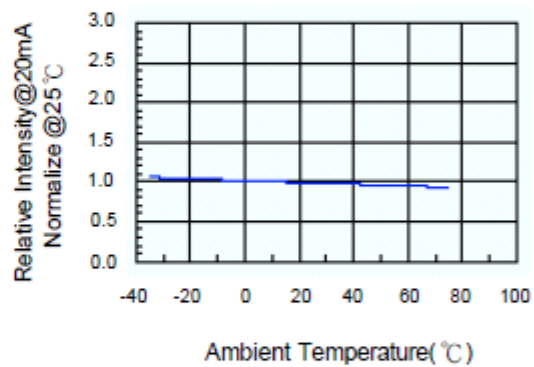

Fig.5 Luminous Spectrum (Ta=25 °C)

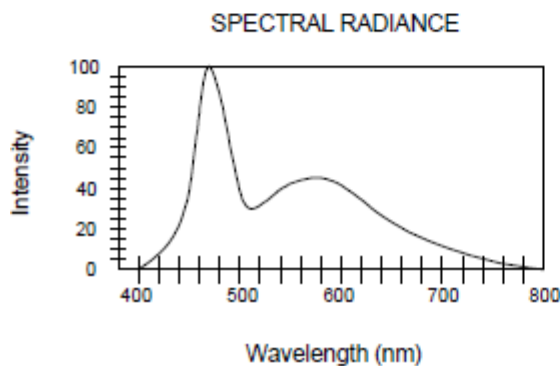
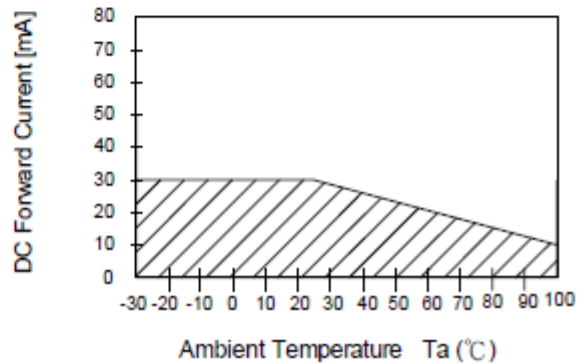
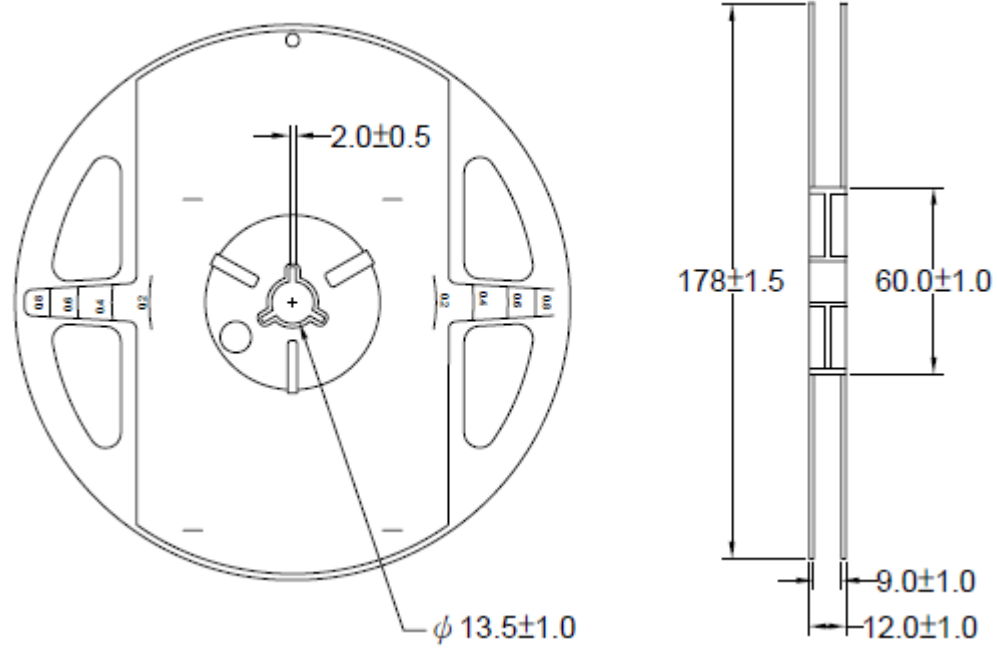
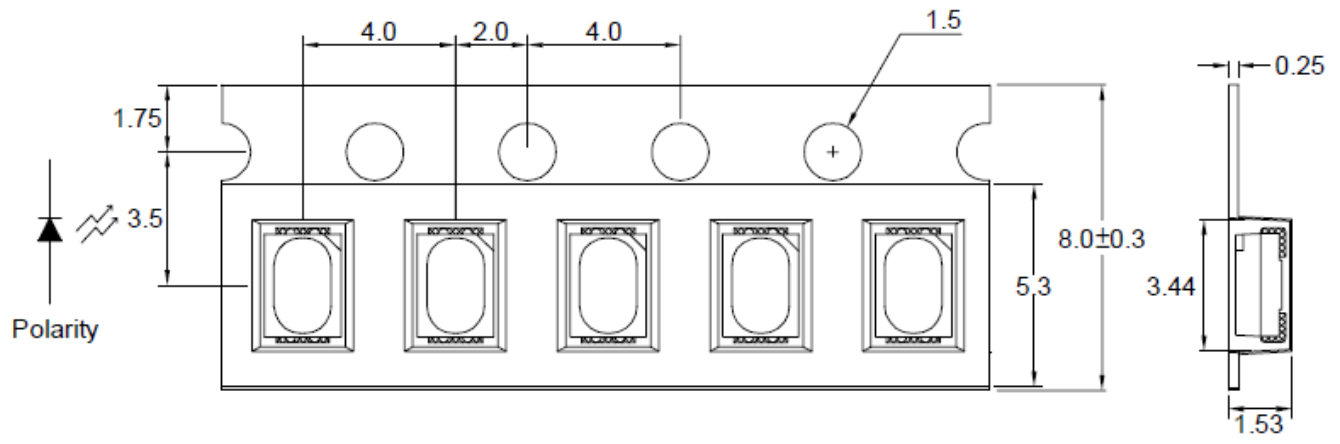

Fig.6 Forward Current vs. Temperature



ChromeLED Corp. reserves the right to make changes at any time in order to supply the best product possible. The most current version of this document will always be available at: www.chromeled.com

PACKAGING SPECIFICATION



- Notes:
1. Tolerance unless mentioned is ±0.1mm, Angle ±0.5, Unit=mm.
 2. 2000pcs / 7" Reel; 8.0mm Tape



RoHS Compliant
Lead Free

ChromeLED Corp. reserves the right to make changes at any time in order to supply the best product possible. The most current version of this document will always be available at: www.chromeled.com

SOLDERING CONDITIONS

RECOMMENDED SOLDERING CONDITIONS

1. Hand Solder
Basic spec is $\leq 320\text{ }^{\circ}\text{C}$ 3 sec one time only.
2. Wave Solder

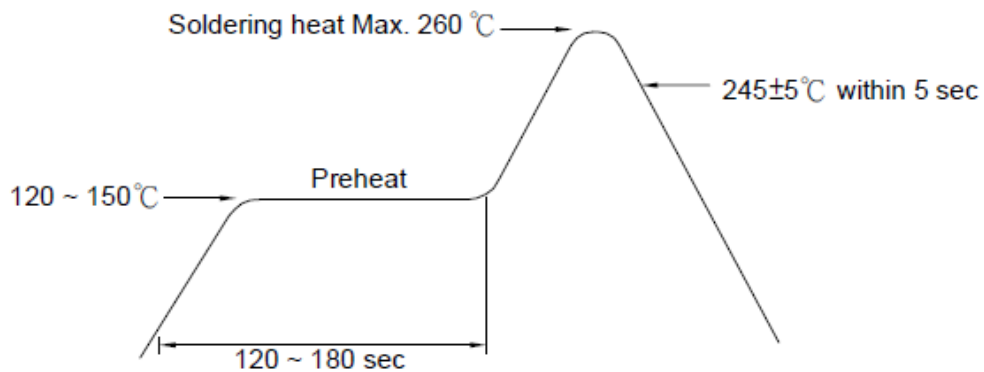

3. PB-Free Reflow Solder

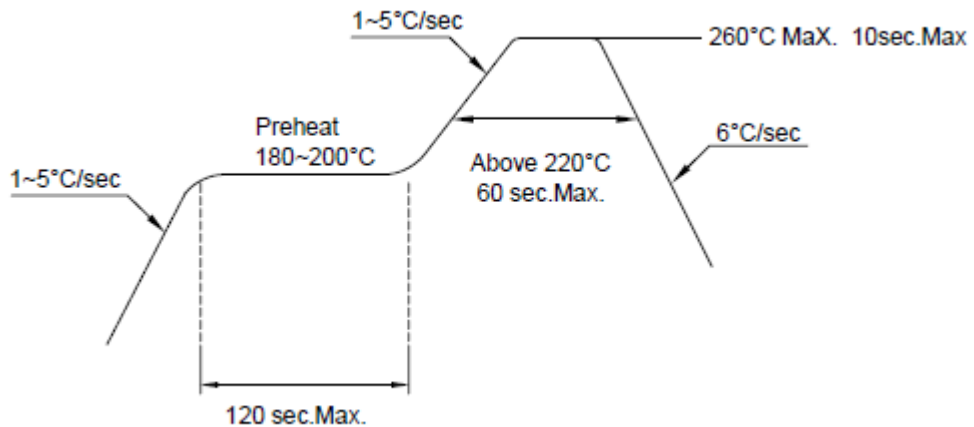

- Reflow soldering should not be done more than two times.
- When soldering, do not put stress on LEDs during heating.
- After soldering, do not warp the circuit board.



ChromeLED Corp. reserves the right to make changes at any time in order to supply the best product possible. The most current version of this document will always be available at: www.chromeled.com