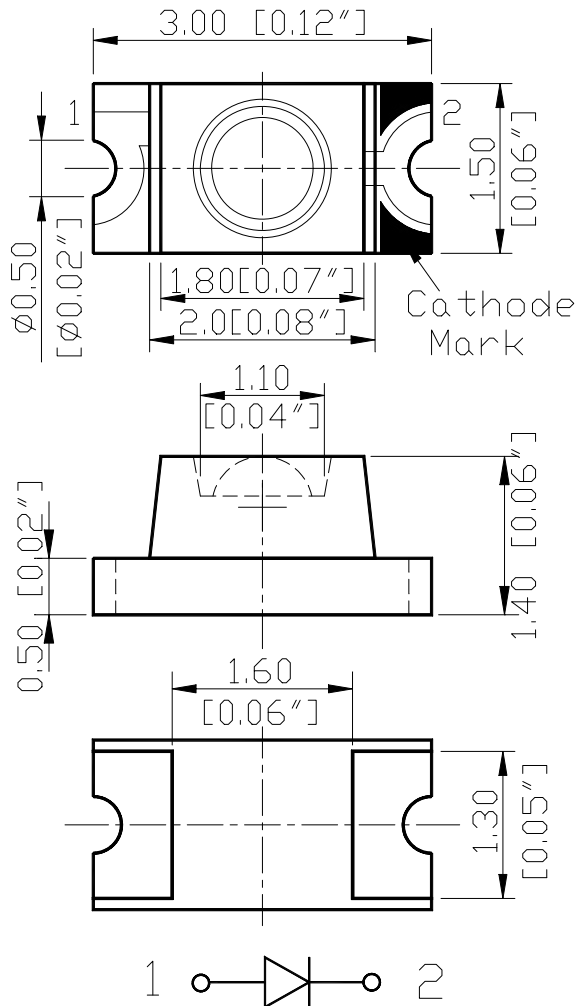
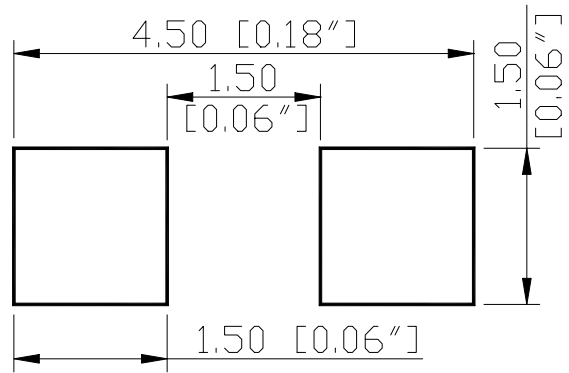

**SPECIFICATION**
**CSL126AB3C**
**PACKAGE OUTLINES**

**RECOMMEND PAD LAYOUT**

ITEM	MATERIALS
Resin (mold)	Epoxy
Lens color	Water transparent
Dice	InGaN
Emitted color	Blue

**Notes:**

1. All dimensions are in millimeters (inches).
2. Tolerance is  $\pm 0.25\text{mm}$  (0.01") unless otherwise noted.
3. Specifications are subject to change without notice.

Part Number	Chip Material	Color of Emission	Lens Type	Viewing Angle
CSL126AB3C	InGaN	Blue	Water Clear	40°



ChromeLED Corp. reserves the right to make changes at any time in order to supply the best product possible. The most current version of this document will always be available at: [www.chromeled.com](http://www.chromeled.com)

**ABSOLUTE MAXIMUM RATINGS**
**(TA=25°C)**

Parameter	Symbol	Max Rating	Unit
Forward Current	I <sub>F</sub>	30	mA
Reverse Current @ 5V	I <sub>R</sub>	10	μA
Power Dissipation	P <sub>d</sub>	111	mW
Operating Temperature Range	T <sub>OP</sub>	-40~+80	°C
Storage Temperature Range	T <sub>STG</sub>	-40~+85	°C
Peak Pulsing Current (1/10 duty f = 10KHz)	I <sub>FP</sub>	125	mA
Soldering Temperature	T <sub>SOL</sub>	Max 260°C for 5 sec Max	

**OPTICAL-ELECTRICAL CHARACTERISTICS**
**(TA=25°C)**

Parameter	Symbol	Test Condition	Value			Unit
			Min	Typ	Max	
Luminous Intensity	I <sub>v</sub>	I <sub>F</sub> = 20mA	400	690	-	mcd
Forward Voltage	V <sub>F</sub>	I <sub>F</sub> = 20mA	-	3.2	3.7	V
Reverse Leakage Current	I <sub>R</sub>	V <sub>R</sub> = 5V	-	-	10	μA
Viewing Angle at 50% I <sub>v</sub>	2θ <sub>1/2</sub>	I <sub>F</sub> = 20mA	-	40	-	Deg
Peak Wavelength	λ <sub>P</sub>	I <sub>F</sub> = 20mA	-	460	-	nm
Dominant Wavelength	λ <sub>D</sub>	I <sub>F</sub> = 20mA	-	470	-	nm

\*Tolerance of viewing angle: -10 / +5 deg.



ChromeLED Corp. reserves the right to make changes at any time in order to supply the best product possible. The most current version of this document will always be available at: [www.chromeled.com](http://www.chromeled.com)

OPTICAL CHARACTERISTIC CURVES

Relative Intensity vs. Wavelength

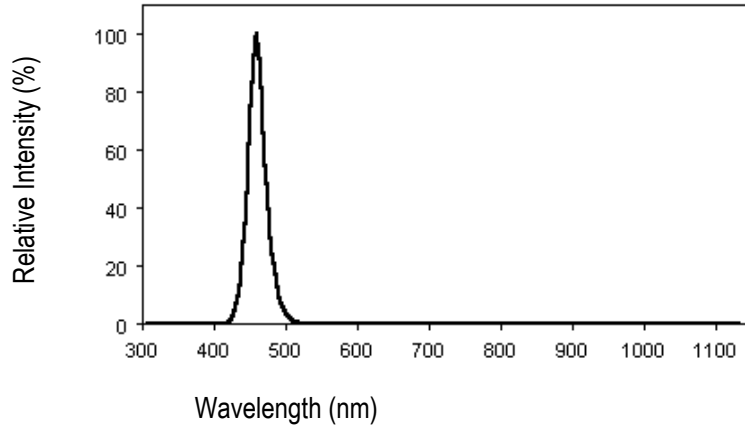

Forward Current vs. Forward Voltage

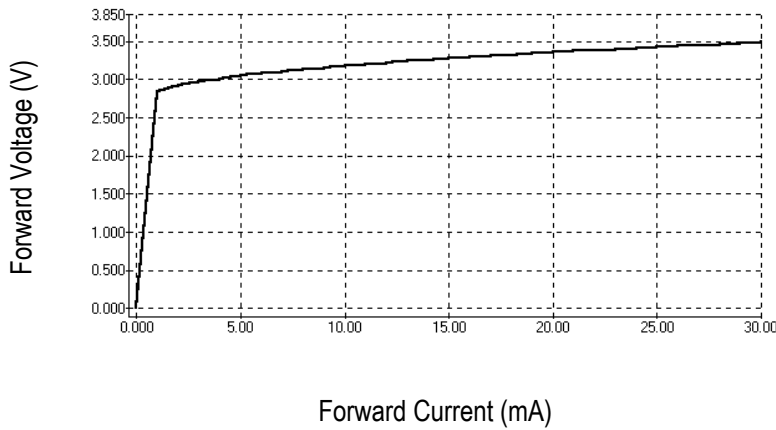

Directive Characteristics

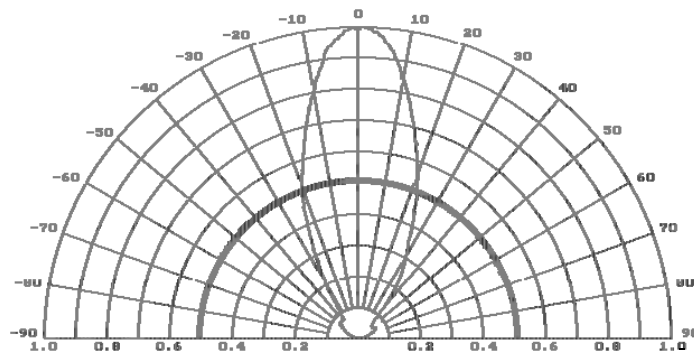

ChromeLED Corp. reserves the right to make changes at any time in order to supply the best product possible. The most current version of this document will always be available at: [www.chromeled.com](http://www.chromeled.com)

## PACKAGING SPECIFICATION

- Feeding Direction

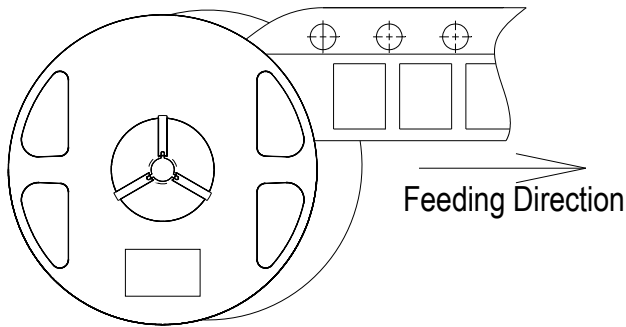

- Dimensions of Reel (Unit: mm)

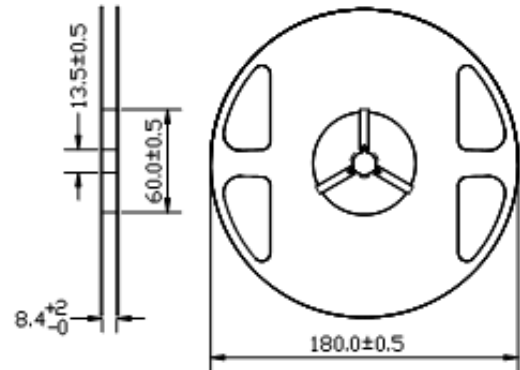

- Dimensions of Tape (Unit: mm)

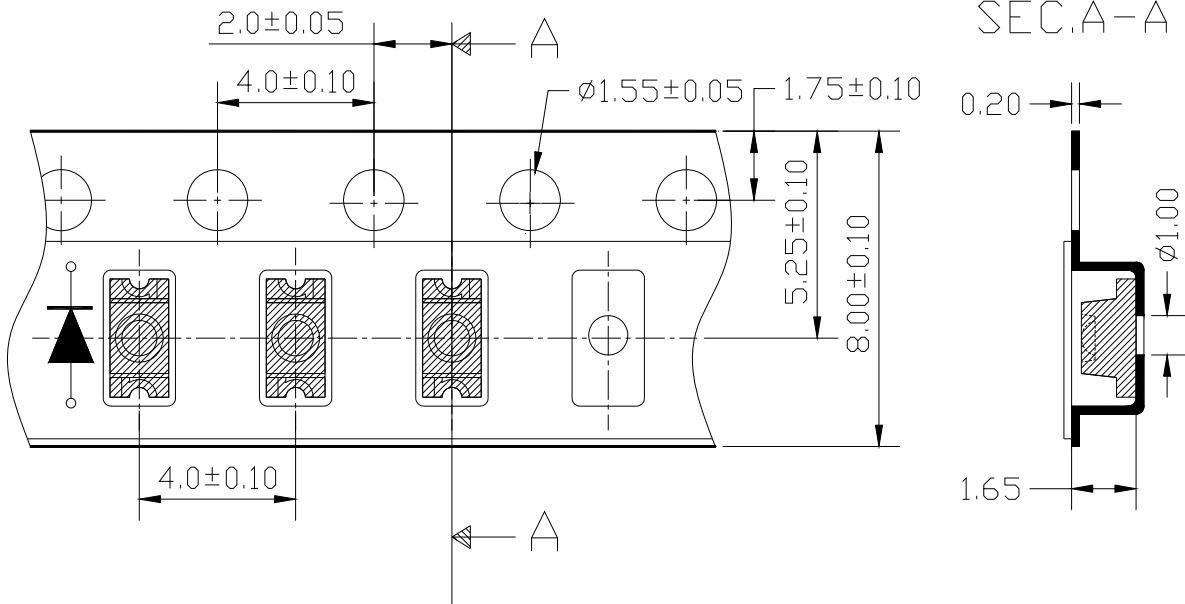

Notes:

1. Empty component pockets are sealed with top cover tape;
2. The maximum number of missing lamps is two;
3. The cathode is oriented towards the tape sprocket hole.
4. 3,000pcs/Reel



ChromeLED Corp. reserves the right to make changes at any time in order to supply the best product possible. The most current version of this document will always be available at: [www.chromeled.com](http://www.chromeled.com)

# SOLDERING CONDITIONS

## RECOMMENDED Sn-PB IR-Reflow Soldering Profile



## RECOMMENDED Pb-Free Soldering Profile



ChromeLED Corp. reserves the right to make changes at any time in order to supply the best product possible. The most current version of this document will always be available at: [www.chromeled.com](http://www.chromeled.com)