

SPECIFICATION **CLB50G2Y2WCA**
PACKAGE OUTLINES
Description

- *Round Type Dual Color
- *T1-3/4 (5mm) Diameter
- *Lens Color: White Diffused
- *With Flange

Features

- *Emitting Color: Green/Yellow
- *High Luminous Intensity
- *Technology: InGaAlP/InGaN
- *Dominant Wavelength = 565/585nm

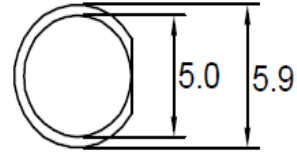
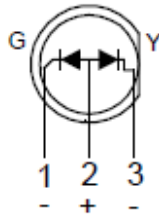

1. CATHODE GREEN
2. COMMON ANODE
3. CATHODE YELLOW

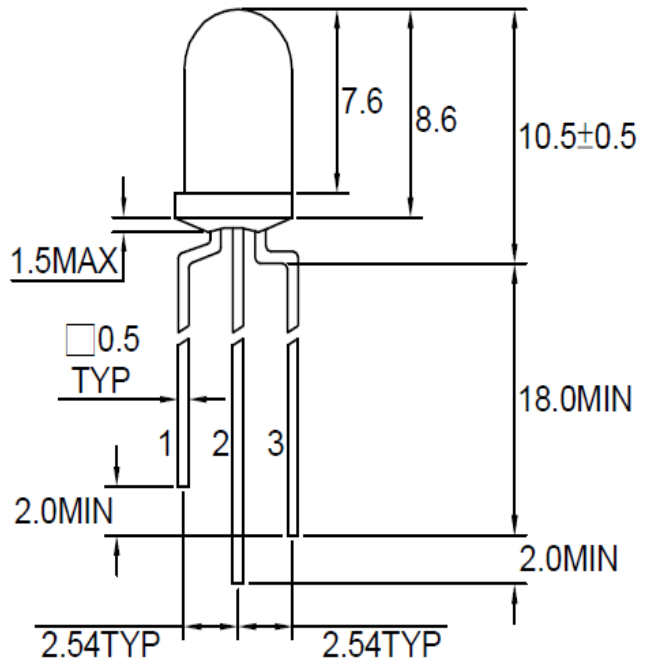

- Notes:
1. All dimensions are in millimeters (inches).
 2. Tolerance is $\pm 0.25\text{mm}$ (0.01") unless otherwise noted.
 3. Specifications are subject to change without notice.

Part Number	Chip Material	Color of Emission	Lens Type	Viewing Angle
CLB50G2Y2WCA	InGaAlP	Green	White Diffused	76°
	InGaAlP	Yellow		



ChromeLED Corp. reserves the right to make changes at any time in order to supply the best product possible. The most current version of this document will always be available at: www.chromeled.com

ABSOLUTE MAXIMUM RATINGS
(TA=25°C)

Parameter	Symbol	Max Rating		Unit
		Green	Yellow	
Forward Current	I _F	30	20	mA
Peak Pulsing Current (1/10 duty f = 10KHz)	I _{FP}	120	80	mA
Power Dissipation	P _d	100	60	mW
Reverse Current @ 5V	I _R	10		μA
Operating Temperature Range	T _{OP}	-40~+85		°C
Storage Temperature Range	T _{STG}	-40~+90		°C
Soldering Temperature	T _{SOL}	Max 260°C for 5 sec Max		

OPTICAL-ELECTRICAL CHARACTERISTICS
(TA=25°C)

Parameter	Symbol	Test Condition	Color	Value			Unit
				Min	Typ	Max	
Luminous Intensity	I _v	I _F = 20mA	G	12	21	-	mcd
			Y	15	28		
Forward Voltage	V _F	I _F = 20mA	G	-	2.2	2.6	V
			Y	-	2.2	2.4	
Viewing Angle at 50% I _v	2θ _{1/2}	I _F = 20mA	-	-	76	-	Deg
Peak Wavelength	λ _P	I _F = 20mA	G	-	568	-	nm
			Y		589		
Dominant Wavelength	λ _D	I _F = 20mA	G	-	565	-	nm
			Y		585		

*Tolerance of viewing angle: -10 / +5 deg.



ChromeLED Corp. reserves the right to make changes at any time in order to supply the best product possible. The most current version of this document will always be available at: www.chromeled.com

OPTICAL CHARACTERISTIC CURVES - GREEN

Fig.1 Forward current vs. Forward Voltage

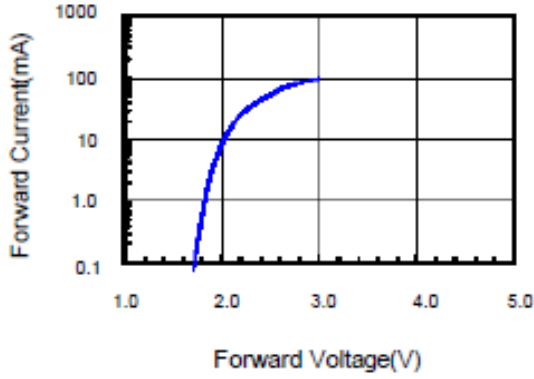

Fig.2 Relative Intensity vs. Forward Current

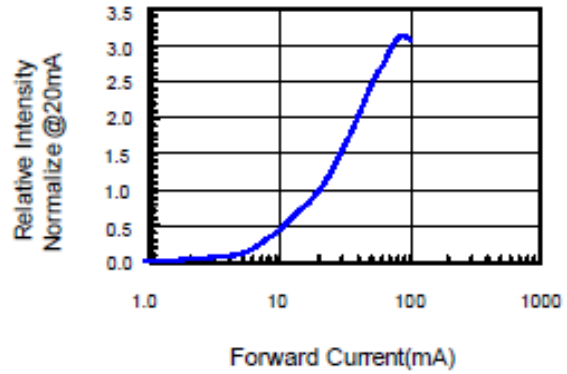

Fig.3 Forward Voltage vs. Temperature

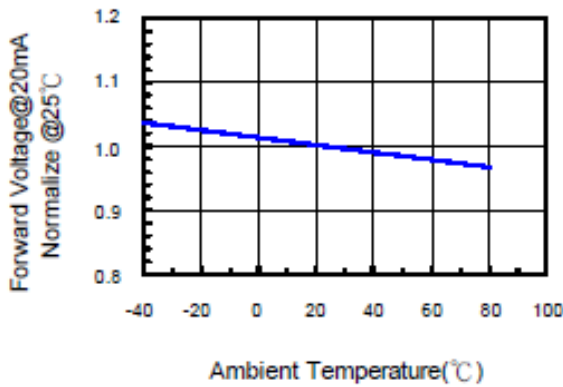

Fig.4 Relative Intensity vs. Temperature

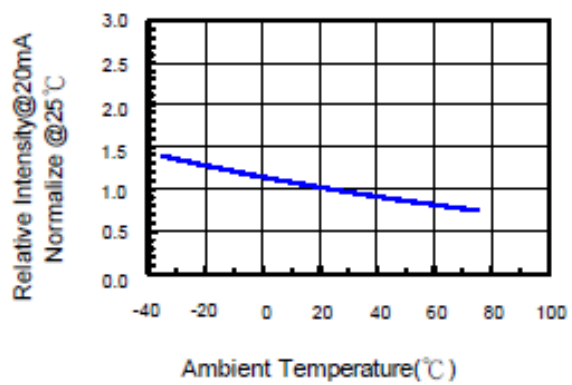
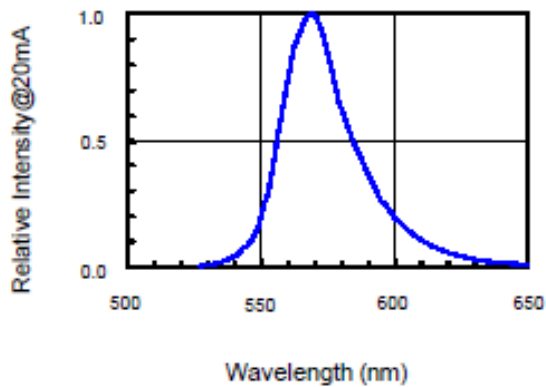

Fig.5 Relative Intensity vs. Wavelength



ChromeLED Corp. reserves the right to make changes at any time in order to supply the best product possible. The most current version of this document will always be available at: www.chromeled.com

OPTICAL CHARACTERISTIC CURVES - YELLOW

Fig.1 Forward current vs. Forward Voltage

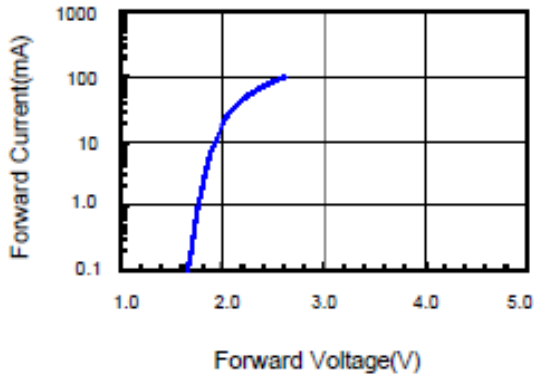

Fig.2 Relative Intensity vs. Forward Current

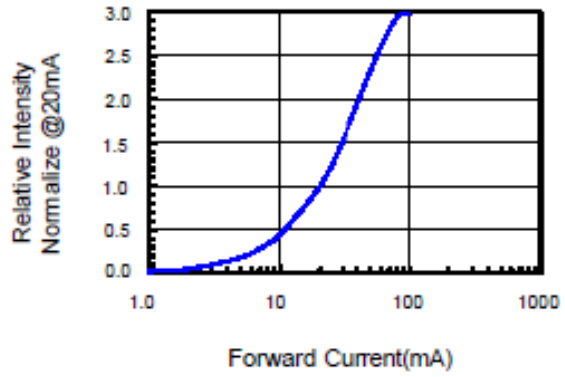

Fig.3 Forward Voltage vs. Temperature

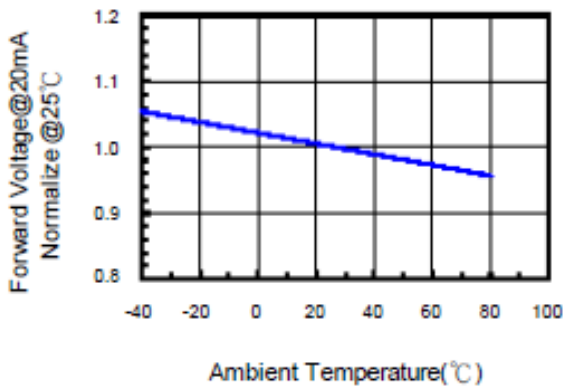

Fig.4 Relative Intensity vs. Temperature

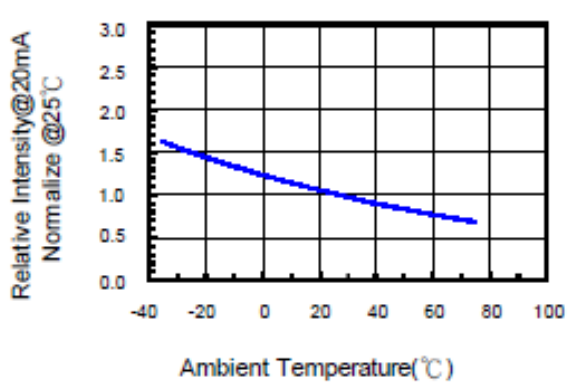
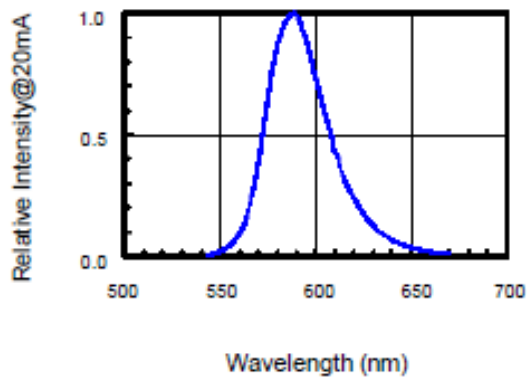

Fig.5 Relative Intensity vs. Wavelength



ChromeLED Corp. reserves the right to make changes at any time in order to supply the best product possible. The most current version of this document will always be available at: www.chromeled.com

SOLDERING CONDITIONS - LEAD FREE

1. Iron:

Soldering Iron: 30W Max
 Temperature 350°C Max
 Soldering Time: 3 Seconds Max (One Time Only)
 Distance: 2mm Mn (From Solder Joint to Body)

2. Wave Soldering Profile

Dip Soldering
 Preheat: 120°C Max
 Preheat Time: 60 Seconds Max
 Ramp-up
 2°C/sec (max)
 Ramp-Down:-5°C/sec (max)
 Solder Bath: 265±5°C Max
 Dipping Time: 5 Seconds Max
 Distance: 2mm Min (From Solder Joint to Body)

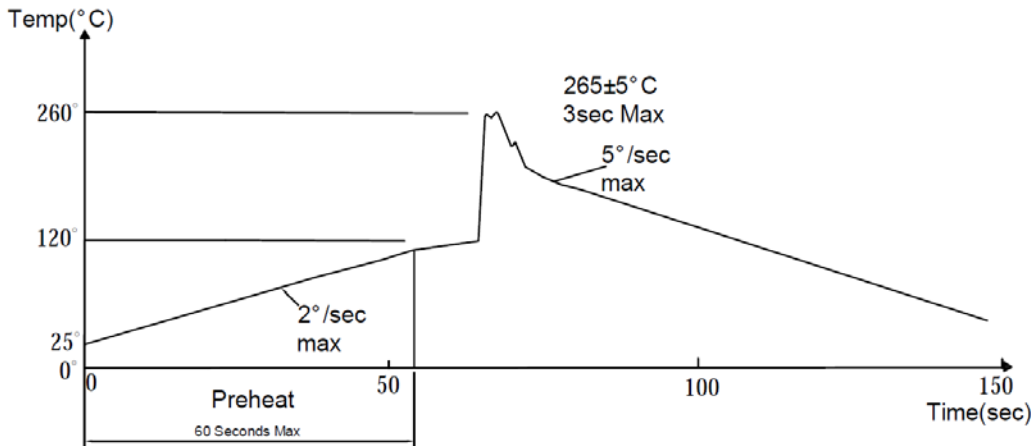

Note:

1. Wave solder should not be made more than one time.
2. You can only select one of the soldering conditions above.



ChromeLED Corp. reserves the right to make changes at any time in order to supply the best product possible. The most current version of this document will always be available at: www.chromeled.com