

**SPECIFICATION**
**CSHF1311W4C40**
**PACKAGE OUTLINES**

**Notes:**

1. All dimensions are in millimeters (inches).
2. Tolerance is  $\pm 0.25$ mm (0.01") unless otherwise noted.
3. Specifications are subject to change without notice.

Part Number	Chip Material	Color of Emission	Lens Type	Viewing Angle
CSHF1311W4C40	InGaN	Green	Water Clear	120°

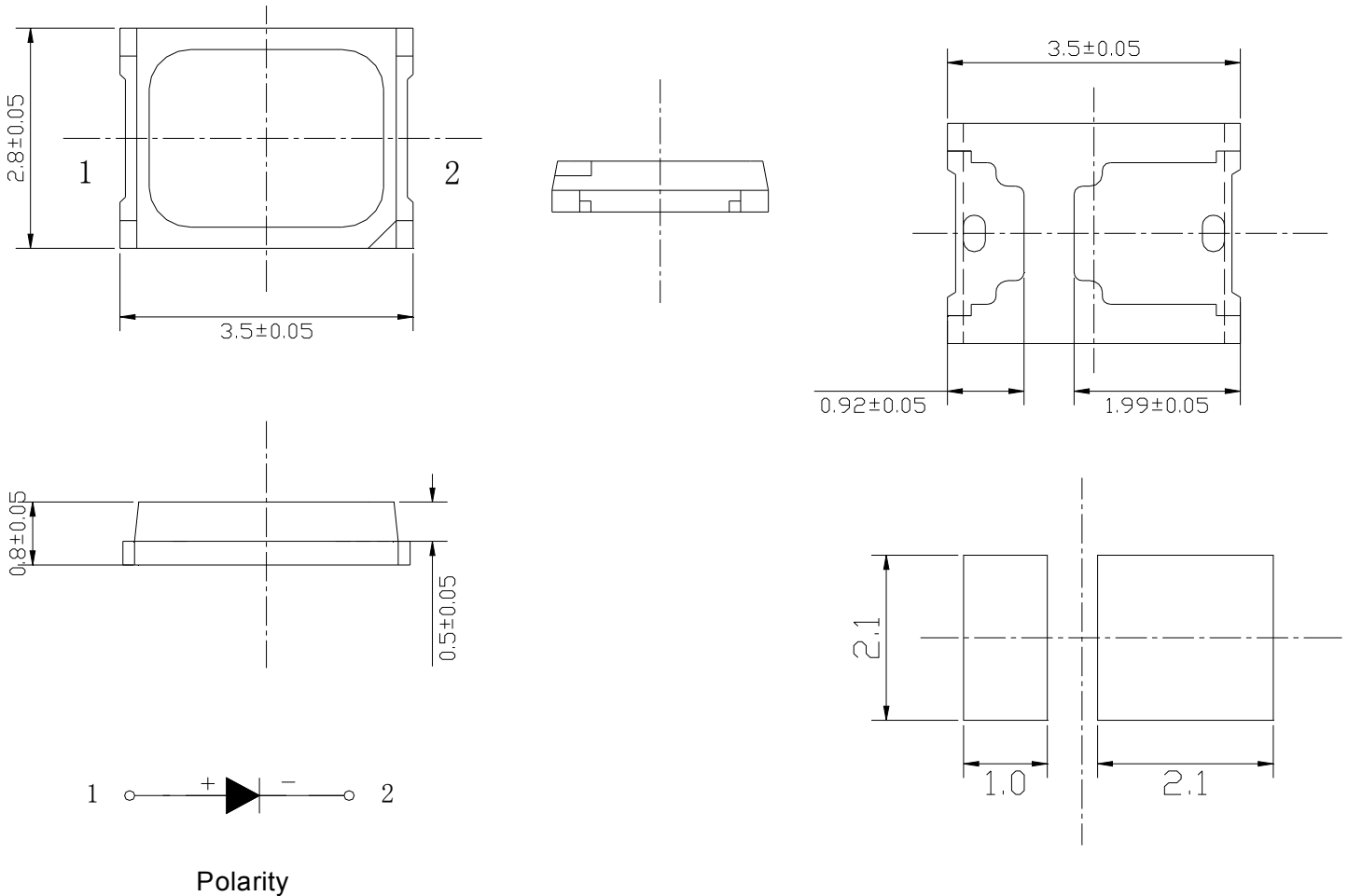

ChromeLED Corp. reserves the right to make changes at any time in order to supply the best product possible. The most current version of this document will always be available at: [www.chromeled.com](http://www.chromeled.com)

**ABSOLUTE MAXIMUM RATINGS**
**(TA=25°C)**

Parameter	Symbol	Max Rating	Unit
Forward Current	IF	60	mA
Reverse Current @ 5V	IR	10	μA
Operating Temperature Range	TOP	-40~+85	°C
Storage Temperature Range	TSTG	-40~+100	°C
Peak Pulsing Current (1/10 duty f = 10KHz)	IFP	120	mA
Soldering Temperature	TSOL	Max 260°C for 5 sec Max	

**OPTICAL-ELECTRICAL CHARACTERISTICS**
**(TA=25°C)**

Parameter	Symbol	Test Condition	Value			Unit
			Min	Typ	Max	
Luminous Intensity	Iv	IF = 60mA	28	30	-	lm
Forward Voltage	VF	IF = 60mA	-	2.8	3.0	V
Reverse Leakage Current	IR	VR = 5V	-	-	10	μA
Viewing Angle at 50% Iv	2θ1/2	IF = 60mA	-	120	-	Deg
Color Rendering Index	CRI	IF = 60mA	81	85	-	-
Correlated Color Temperature	CCT	IF = 60mA	3616	-	4125	K

\*Tolerance of viewing angle: -10 / +5 deg.



ChromeLED Corp. reserves the right to make changes at any time in order to supply the best product possible. The most current version of this document will always be available at: [www.chromeled.com](http://www.chromeled.com)

## OPTICAL CHARACTERISTIC CURVES

**Fig.1-Forward Voltage Vs. Forward Current**  
伏安特性曲线

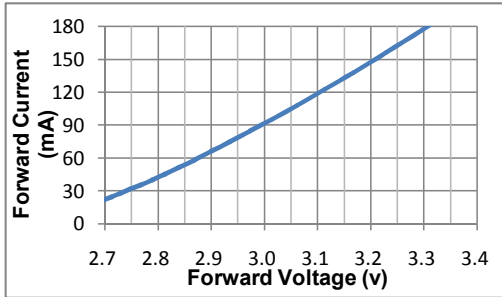

**Fig.2-Forward Current Vs. Relative Intensity**  
正向电流与相对光强特性曲线

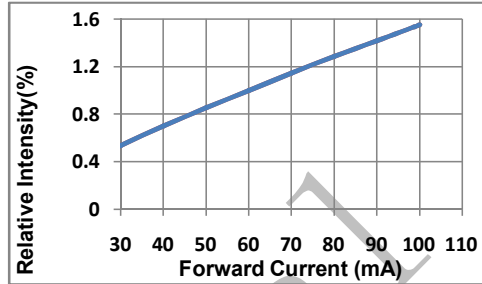

**Fig.3-Ambient Temperature Vs. Relative Intensity**  
环境温度与相对光强特性曲线

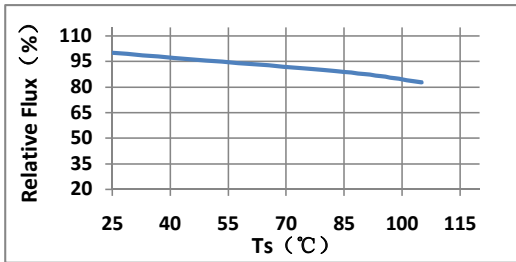

**Fig.4-Ambient Temperature Vs. Forward Current**  
环境温度与正向电流特性曲线

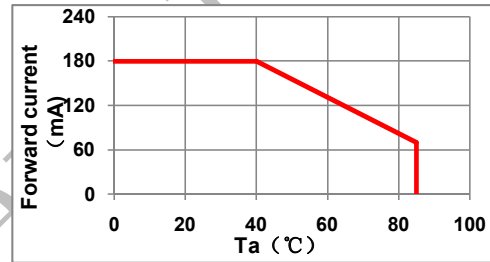

**Fig.5-Forward Voltage Vs. Ambient Temperature**  
电压与环境温度特性曲线

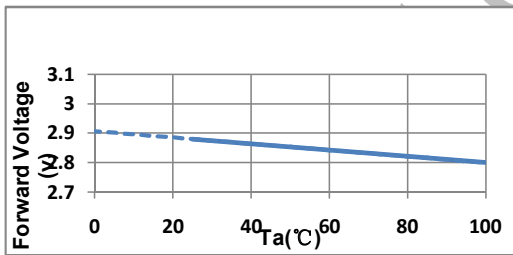

**Fig.6-Radiation diagram**  
辐射特性曲线

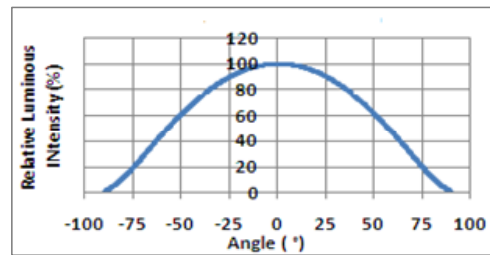

**Fig.7-Chromaticity Coordinate Vs. Ambient Temperature**  
色坐标与环境温度特性曲线

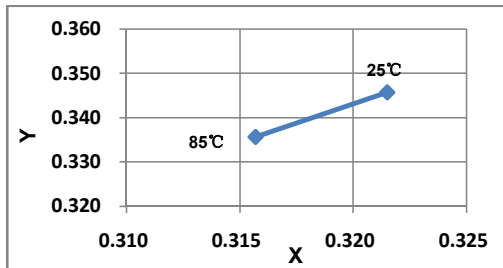

**Fig.8- Spectrum Distribution**  
光谱分布特性曲线

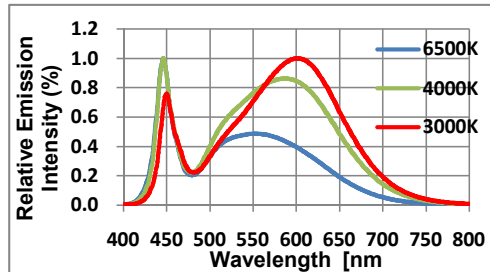

ChromeLED Corp. reserves the right to make changes at any time in order to supply the best product possible. The most current version of this document will always be available at: [www.chromeled.com](http://www.chromeled.com)

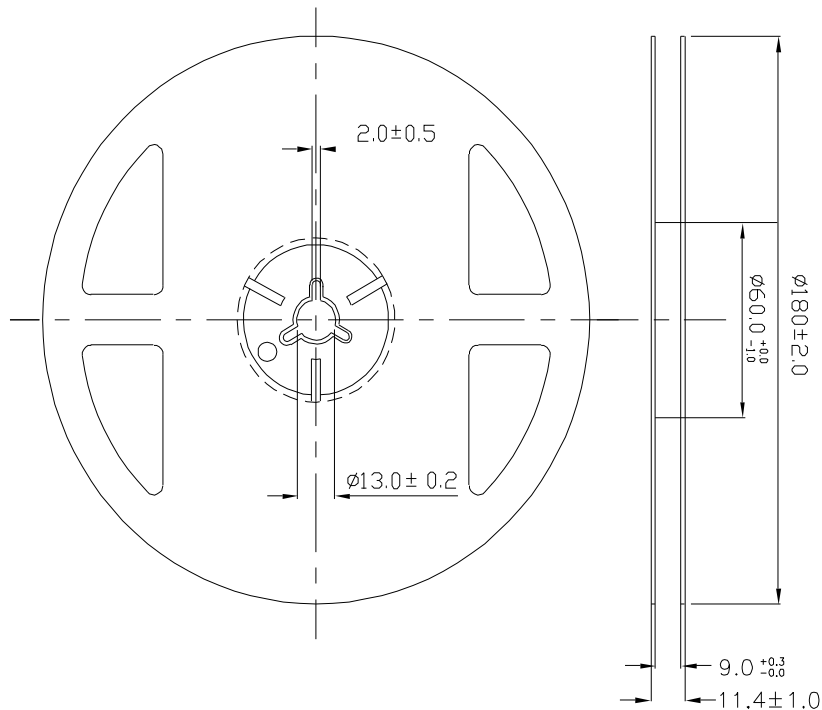
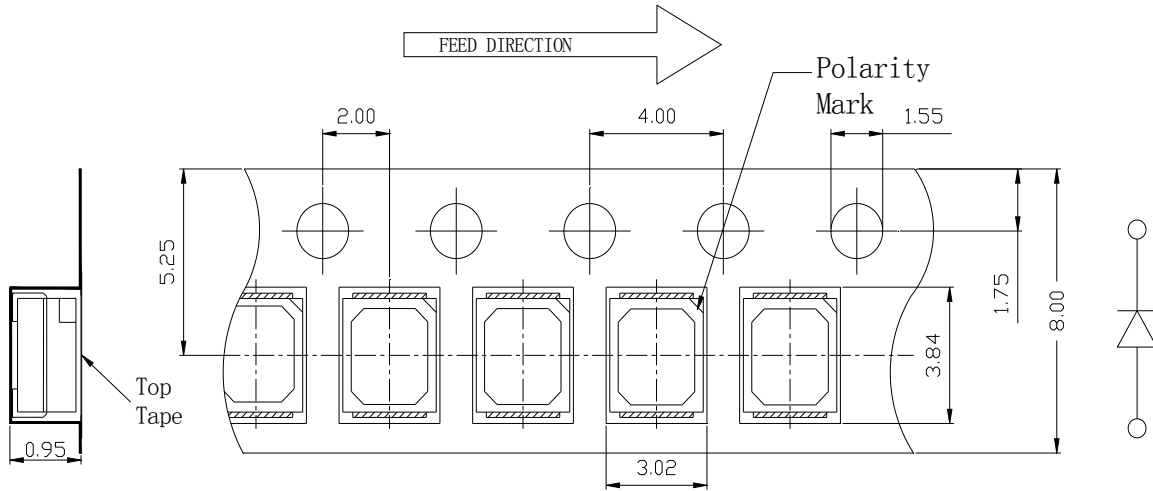
**PACKAGING SPECIFICATION**
**Carrier Tape Dimensions**

**NOTES**

1. Empty component pockets are sealed with top cover tape;
2. The maximum number of missing lamps is two;
3. The cathode is oriented towards the tape sprocket hole in accordance with ANSI/EIA RS-481 specifications.
4. 3,000 pcs/ Reel.



ChromeLED Corp. reserves the right to make changes at any time in order to supply the best product possible. The most current version of this document will always be available at: [www.chromeled.com](http://www.chromeled.com)

## SOLDERING CONDITIONS

### Reflow profile

- Soldering condition
  - Recommended soldering conditions

Reflow Soldering		Hand Soldering	
Pre-heat	160~180°C	Temperature	300°C Max.
Pre-heat time	120 seconds Max.	Soldering time	3 second Max. (one time only)
Peak temperature	260°C Max.		
Soldering time	10 seconds Max.		
Condition	Refer to Temperature-profile		

- After reflow soldering rapid cooling should be avoided
- Temperature-profile (Surface of circuit board)  
Use the following conditions shown in the figure.

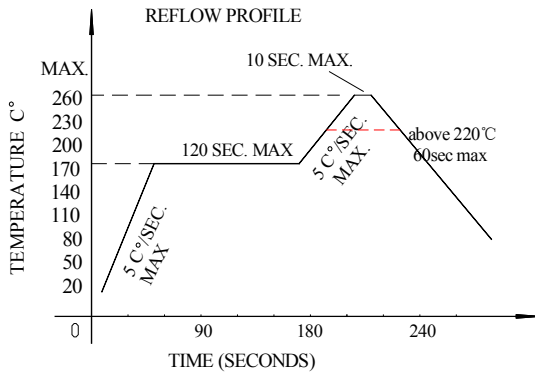

1. Reflow soldering should not be done more than two times
2. When soldering ,do not put stress on the LEDs during heating

### ■ Soldering iron

1. When hand soldering, keep the temperature of the iron under 300°C, and at that temperature keep the time under 3 sec.
2. The hand soldering should be done only a time
3. The basic spec is ≤5 sec. when the temperature of 260°C, do not contact the resin when hand soldering

### ■ Rework

1. Customer must finish rework within 5 sec under 260°C
2. The head of iron can not touch the resin
3. Twin-head type is preferred.

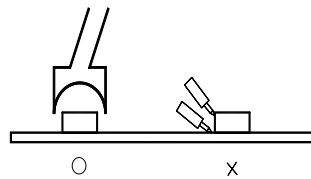

ChromeLED Corp. reserves the right to make changes at any time in order to supply the best product possible. The most current version of this document will always be available at: [www.chromeled.com](http://www.chromeled.com)