

SPECIFICATIONS **CSH66Y3C**
PACKAGE OUTLINES

- Notes:
1. All dimensions are in millimeter (inches).
 2. Tolerance is $\pm 0.25\text{mm}$ (0.01") unless otherwise noted.
 3. Specifications are subject to change without notice.

Part Number	Chip Material	Color of Emission	Lens Type	Viewing Angle
CSH66Y3C	InGaAlP	Yellow	Water Clear	120°

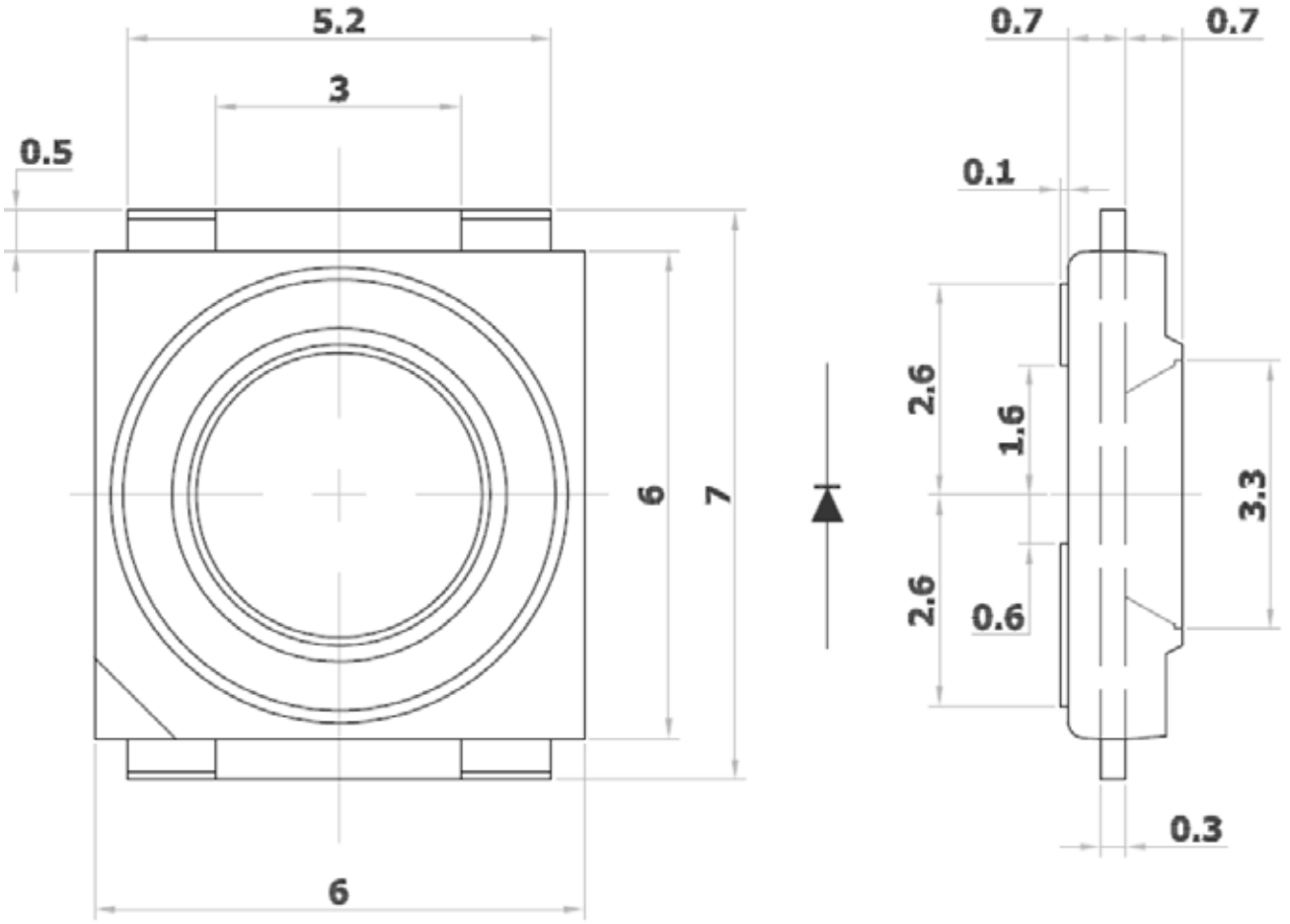

ChromeLED Corp. reserves the right to make changes at any time in order to supply the best product possible. The most current version of this document will always be available at: www.chromeled.com

ABSOLUTE MAXIMUM RATINGS
(TA=25°C)

Parameter	Symbol	Max Rating	Unit
Forward Current	I _F	400	mA
ESD Threshold (HBM)	V	2000	v
Reverse Voltage	V	12	v
Junction Temperature	T _J	125	°C
Operating Temperature Range	T _{OP}	-40~+100	°C
Storage Temperature Range	T _{STG}	-40~+100	°C
Peak Pulsing Current (1/10 duty f = 10KHz)	I _{FP}	500	mA
Soldering Temperature	T _{SOL}	Max 260°C for 5 sec Max	

OPTICAL-ELECTRICAL CHARACTERISTICS
(TA=25°C)

Parameter	Symbol	Test Condition	Value			Unit
			Min	Typ	Max	
Peak Wavelength	λ _P	I _F = 400mA	-	585	-	-
Dominant Wavelength	λ _D	I _F = 400mA	-	588	-	-
Reverse Leakage Current	I _R	V _R = 12V	-	-	100	μA
Forward Voltage	V _F	I _F = 400mA	-	2.5	2.8	V
Luminous Intensity	I _V	I _F = 400mA	9000	14000	-	mcd

*Tolerance of viewing angle: -10 / +5 deg.



ChromeLED Corp. reserves the right to make changes at any time in order to supply the best product possible. The most current version of this document will always be available at: www.chromeled.com

RECOMMENDED SOLDER PAD

Solder Pad Design:

Note: Unit to unit pitching must not be less than 25mm. Metal core circuit board (MCPCB) is highly recommended for high density applications. Please consult sales and marketing for additional information.

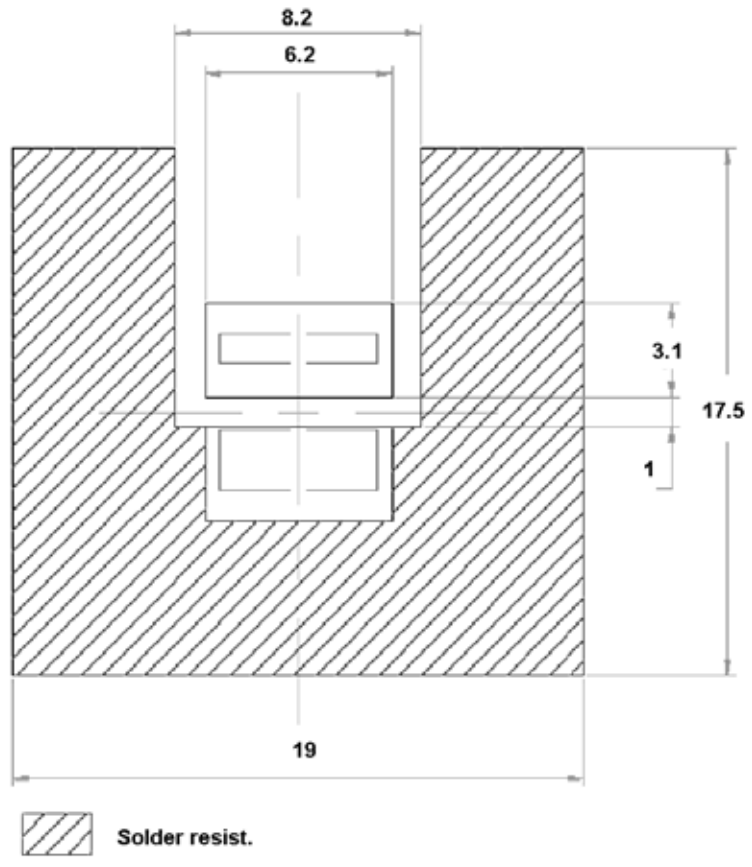

ChromeLED Corp. reserves the right to make changes at any time in order to supply the best product possible. The most current version of this document will always be available at: www.chromeled.com

OPTICAL CHARACTERISTIC CURVES

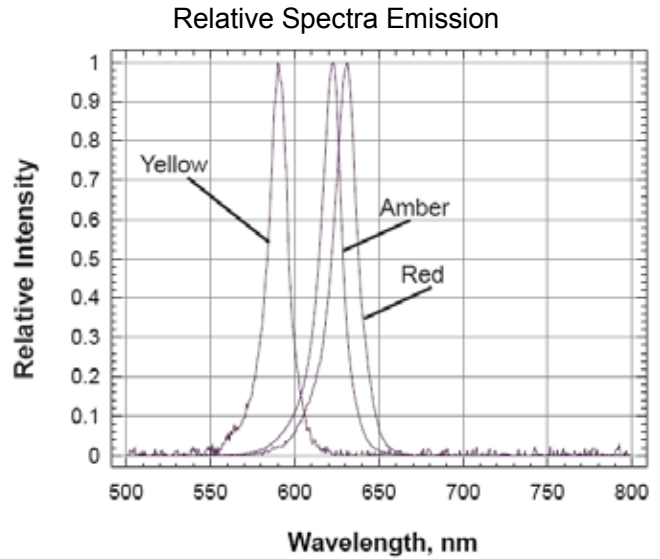
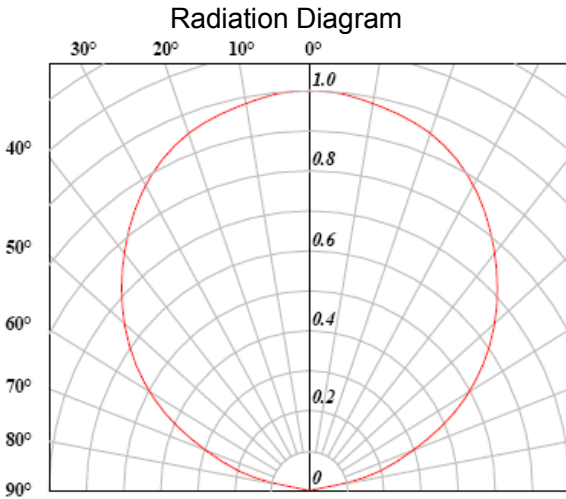

Max. Forward Current vs. Ambient Temp

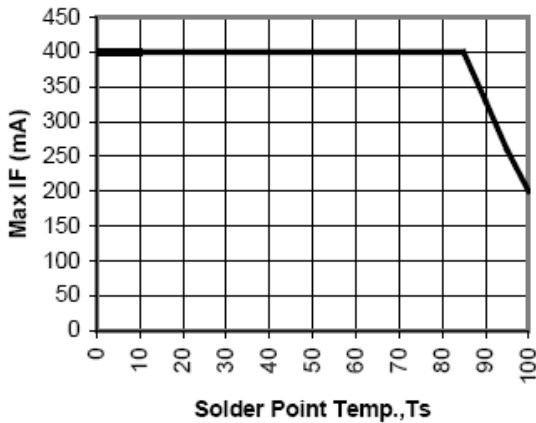

Forward Current vs. Forward Voltage

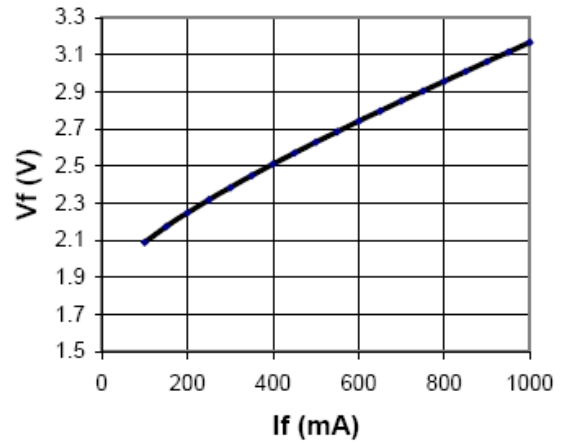

Intensity vs. Forward Current Relative Intensity Normalized @ If = 400 mA

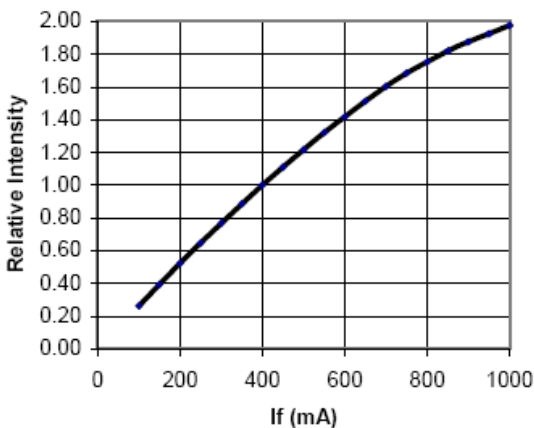

ChromeLED Corp. reserves the right to make changes at any time in order to supply the best product possible. The most current version of this document will always be available at: www.chromeled.com

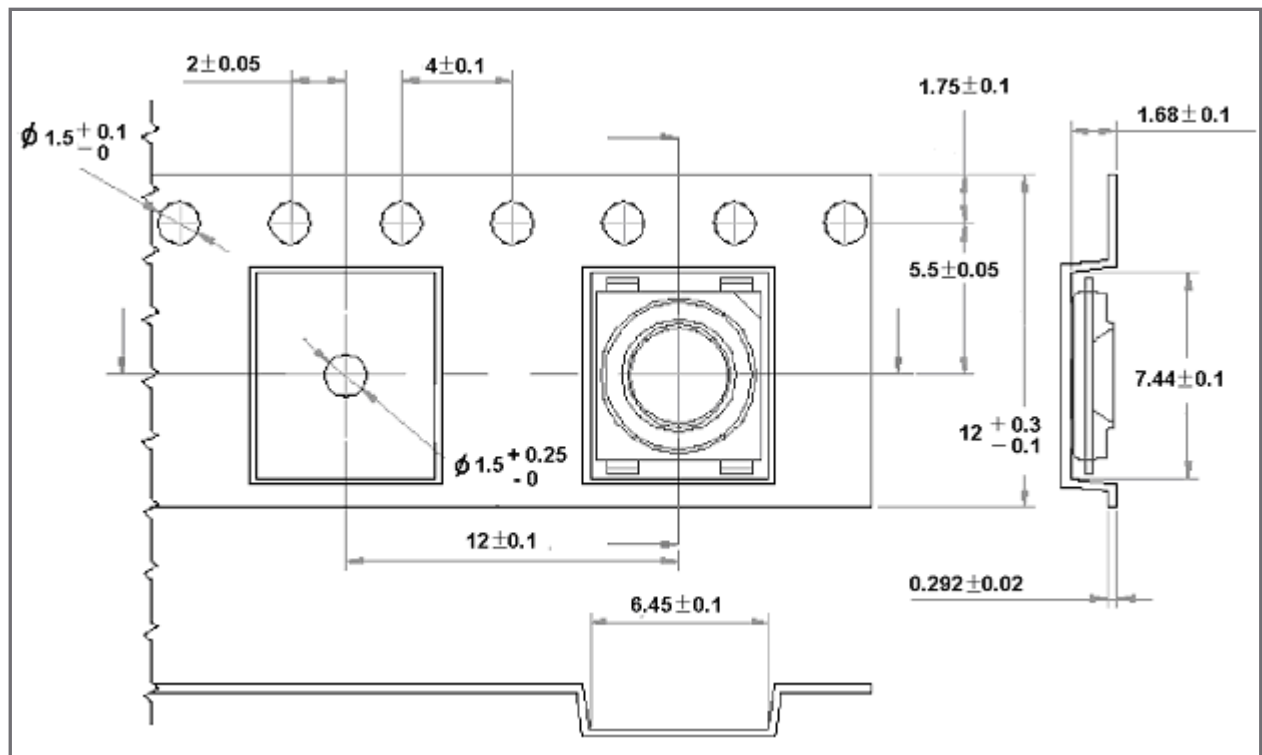
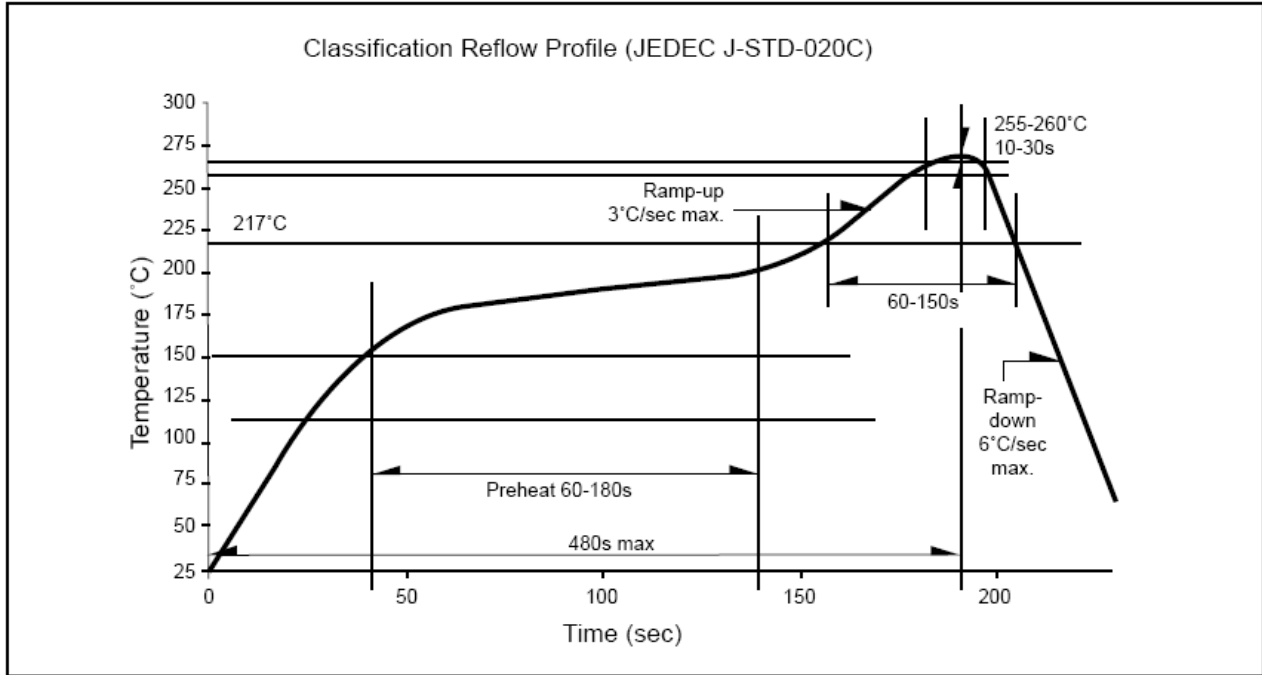
SOLDERING CONDITIONS & TAPING ORIENTATION
RECOMMENDED Pb-Free Soldering Profile

ChromeLED Corp. reserves the right to make changes at any time in order to supply the best product possible. The most current version of this document will always be available at: www.chromeled.com