

SPECIFICATIONS
CSH66GT3ZC
PACKAGE OUTLINES

Notes:

1. All dimensions are in millimeter (inches).
2. Tolerance is $\pm 0.25\text{mm}$ (0.01") unless otherwise noted.
3. Specifications are subject to change without notice.

Part Number	Chip Material	Color of Emission	Lens Type	Viewing Angle
CSH66GT3ZC	InGaN	Green	Water Clear	120°

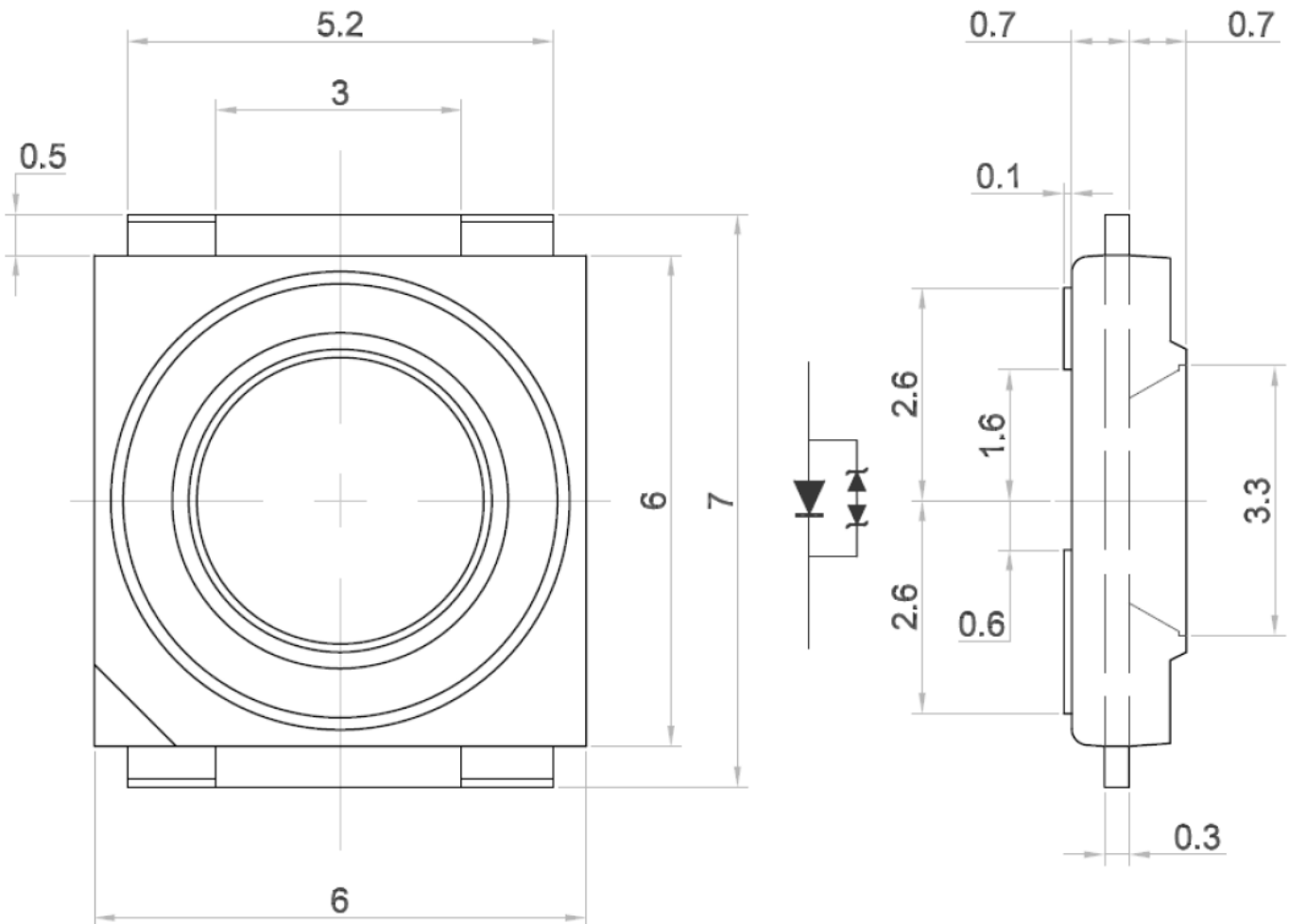

ChromeLED Corp. reserves the right to make changes at any time in order to supply the best product possible. The most current version of this document will always be available at: www.chromeled.com

ABSOLUTE MAXIMUM RATINGS
(TA=25°C)

Parameter	Symbol	Max Rating	Unit
Forward Current	I _F	350	mA
ESD Threshold (HBM)	V	2000	V
Reverse Voltage	V	NA	V
Junction Temperature	T _J	120	°C
Operating Temperature Range	T _{OP}	-40~+100	°C
Storage Temperature Range	T _{STG}	-40~+100	°C
Peak Pulsing Current (1/10 duty f = 10KHz)	I _{FP}	1000	mA
Soldering Temperature	T _{SOL}	Max 260°C for 5 sec Max	

OPTICAL-ELECTRICAL CHARACTERISTICS
(TA=25°C)

Parameter	Symbol	Test Condition	Value			Unit
			Min	Typ	Max	
Peak Wavelength	λ _P	I _F = 350mA	-	520	-	-
Dominant Wavelength	λ _D	I _F = 350mA	-	525	-	-
Reverse Leakage Current	I _R	V _R = 12V	-	-	-	μA
Forward Voltage	V _F	I _F = 350mA	-	3.5	3.8	V
Luminous Intensity	I _V	I _F = 350mA	18000	22400	-	mcd

*Tolerance of viewing angle: -10 / +5 deg.



ChromeLED Corp. reserves the right to make changes at any time in order to supply the best product possible. The most current version of this document will always be available at: www.chromeled.com

RECOMMENDED SOLDER PAD

SOLDER PAD DESIGN:

Note: Unit to unit pitching must not be less than 25mm. Metal core circuit board (MCPCB) is highly recommended for high density applications. Please consult sales and marketing for additional information.

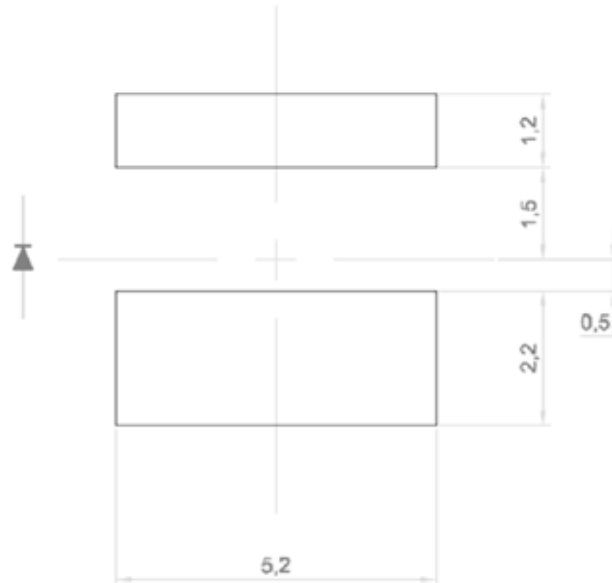

ChromeLED Corp. reserves the right to make changes at any time in order to supply the best product possible. The most current version of this document will always be available at: www.chromeled.com

OPTICAL CHARACTERISTIC CURVES

TYPICAL ELECTRO-OPTICAL CHARACTERISTIC CURVES

Wavelength Vs Forward Current

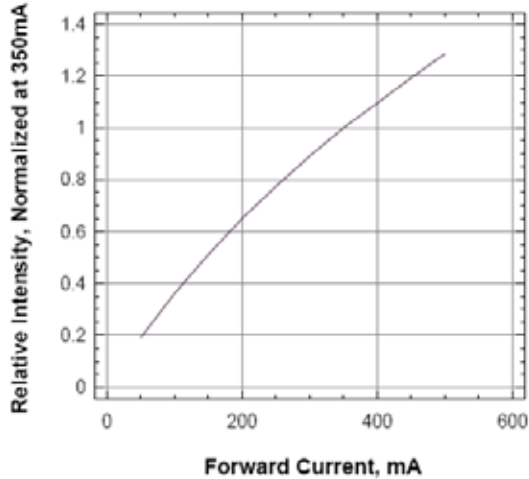

Relative Flux Vs Forward Current

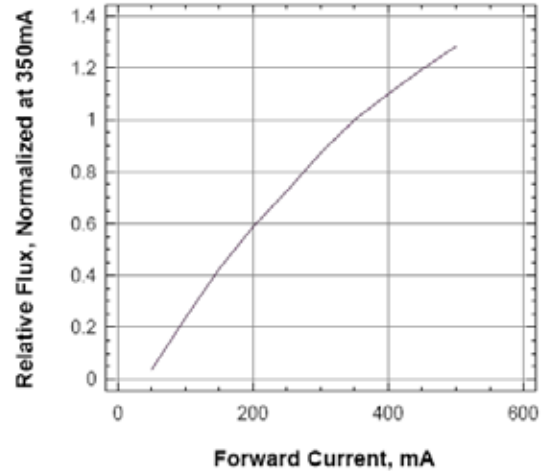

Forward Current Vs Forward Voltage

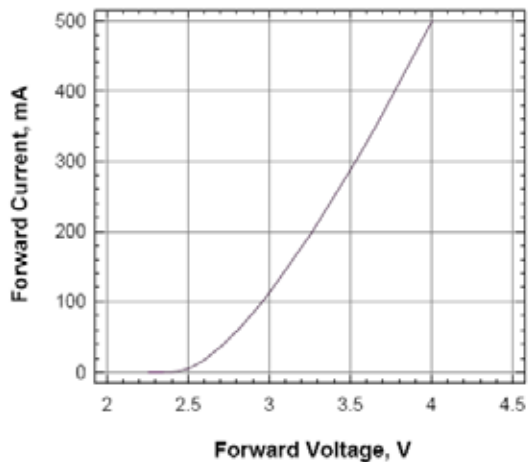

Forward Current Vs Ambient Temperature (R_{ja}=40KW)

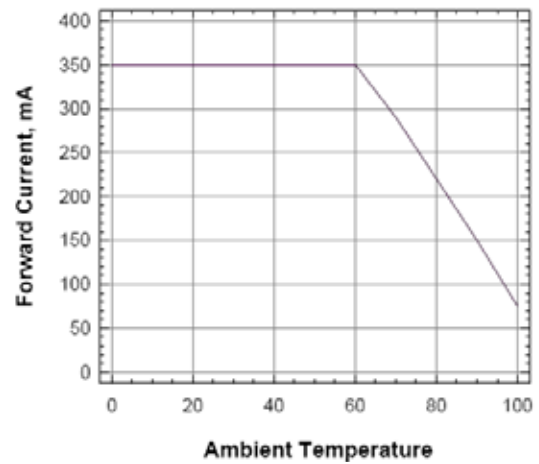

ChromeLED Corp. reserves the right to make changes at any time in order to supply the best product possible. The most current version of this document will always be available at: www.chromeled.com

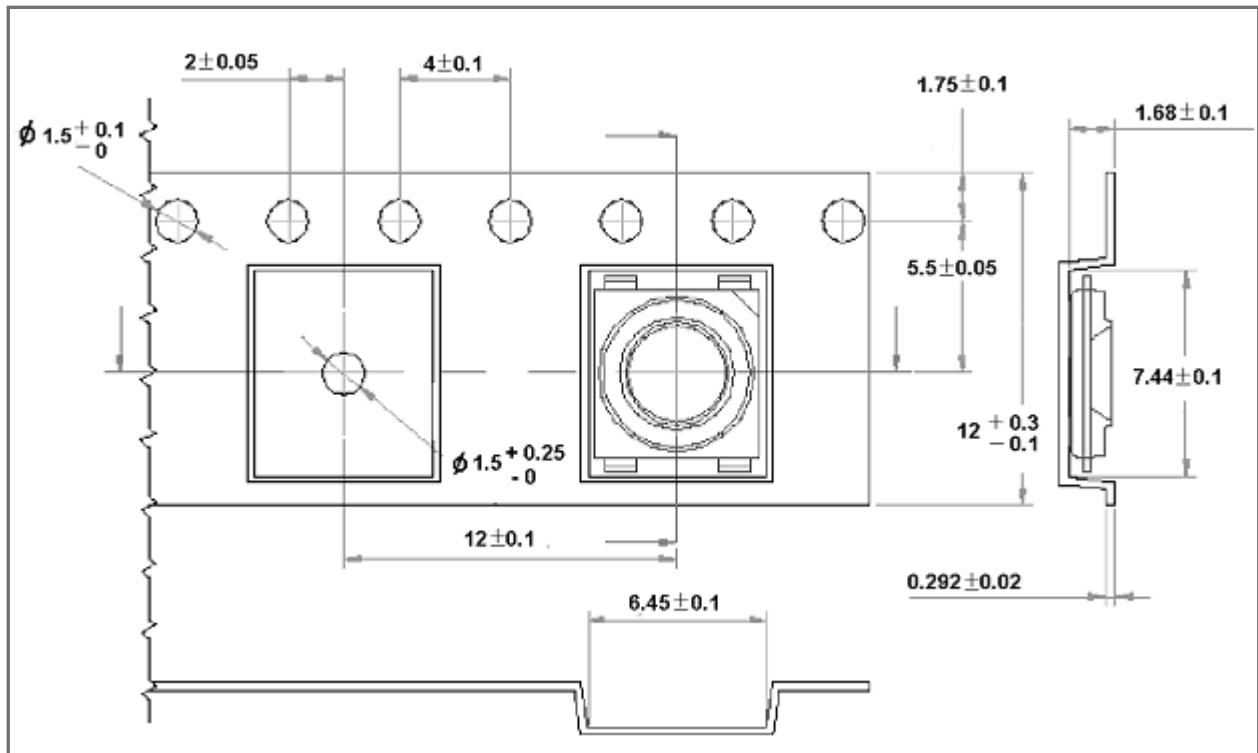
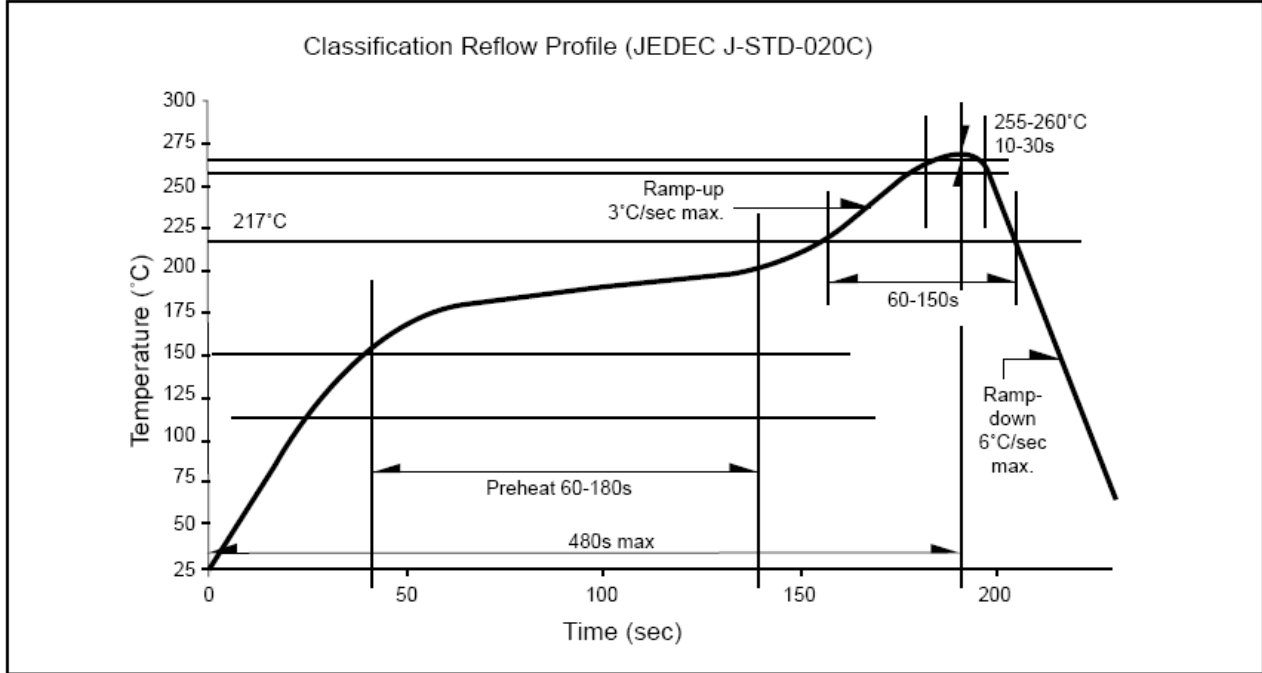
SOLDERING CONDITIONS & TAPING ORIENTATION
RECOMMENDED Pb-Free Soldering Profile

ChromeLED Corp. reserves the right to make changes at any time in order to supply the best product possible. The most current version of this document will always be available at: www.chromeled.com