

SPECIFICATION **CSR84R2C**

PACKAGE OUTLINES

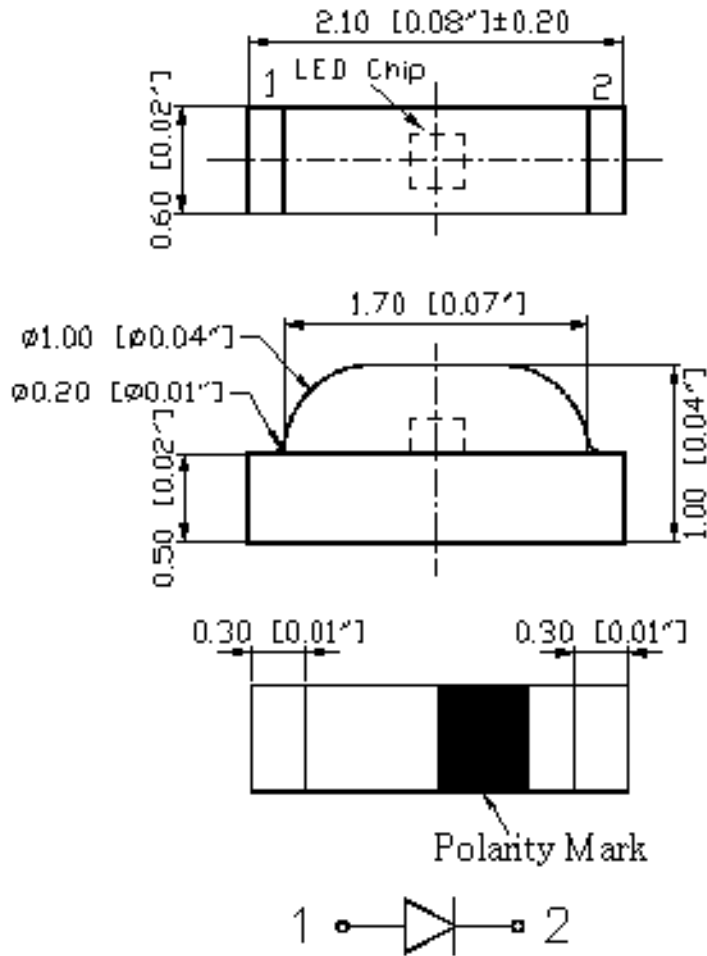

RECOMMEND PAD LAYOUT

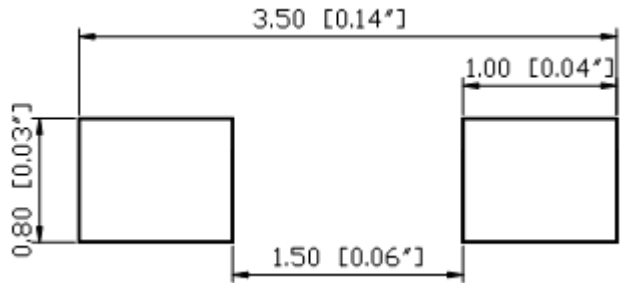

ITEM	MATERIALS
Resin (mold)	Epoxy
Lens color	Water Transparent
Dice	AlGaInP/GaAs
Emitted Color	Red

- Notes:
1. All dimensions are in millimeters (inches).
 2. Tolerance is $\pm 0.25\text{mm}$ ($0.01''$) unless otherwise noted.
 3. Specifications are subject to change without notice.

Part Number	Chip Material	Color of Emission	Lens Type	Viewing Angle
CSR84R2C	InGaAlP	Red	Water Clear	150°



ChromeLED Corp. reserves the right to make changes at any time in order to supply the best product possible. The most current version of this document will always be available at: www.chromeled.com

ABSOLUTE MAXIMUM RATINGS
(TA=25°C)

Parameter	Symbol	Max Rating	Unit
Forward Current	I _F	30	mA
Reverse Current @ 5V	I _R	10	μA
Power Dissipation	P _d	75	mW
Operating Temperature Range	T _{OP}	-40~+80	°C
Storage Temperature Range	T _{STG}	-40~+85	°C
Peak Pulsing Current (1/10 duty f = 10KHz)	I _{FP}	125	mA
Soldering Temperature	T _{SOL}	Max 260°C for 5 sec Max	

OPTICAL-ELECTRICAL CHARACTERISTICS
(TA=25°C)

Parameter	Symbol	Test Condition	Value			Unit
			Min	Typ	Max	
Luminous Intensity	I _v	I _F = 20mA	50	85	-	mcd
Forward Voltage	V _F	I _F = 20mA	-	2.0	2.5	V
Reverse Leakage Current	I _R	V _R = 5V	-	-	10	μA
Viewing Angle at 50% I _v	2θ _{1/2}	I _F = 20mA	-	150	-	Deg
Peak Wavelength	λ _P	I _F = 20mA	-	640	-	nm
Dominant Wavelength	λ _D	I _F = 20mA	-	630	-	nm

*Tolerance of viewing angle: -10 / +5 deg.



ChromeLED Corp. reserves the right to make changes at any time in order to supply the best product possible. The most current version of this document will always be available at: www.chromeled.com

OPTICAL CHARACTERISTIC CURVES

Relative Intensity vs. Wavelength

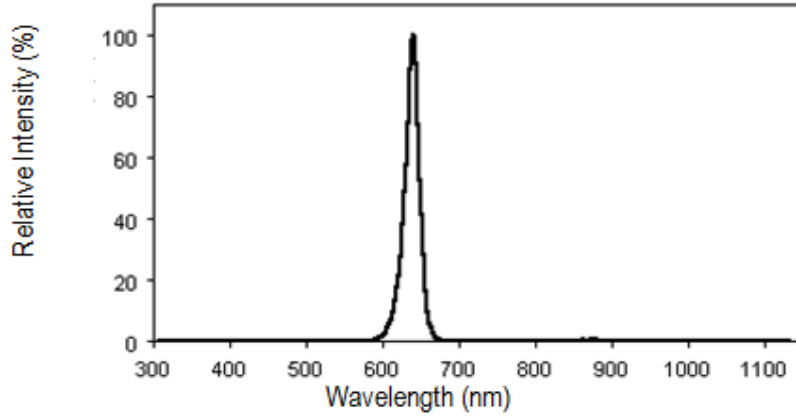

Forward Current vs. Forward Voltage

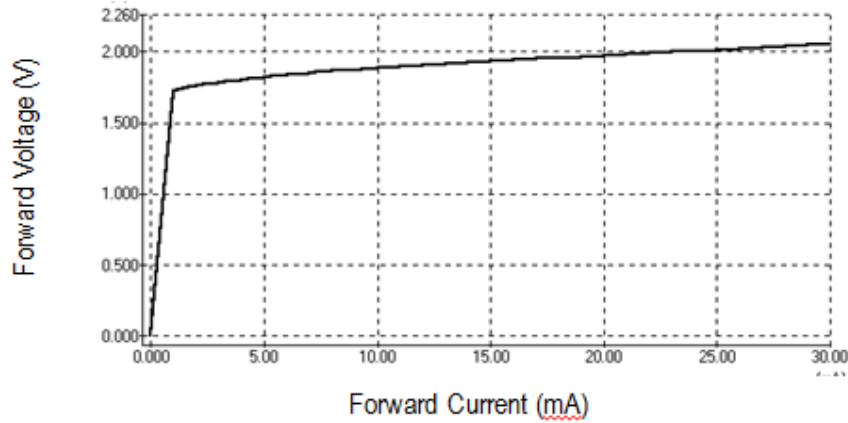

Directive Characteristics

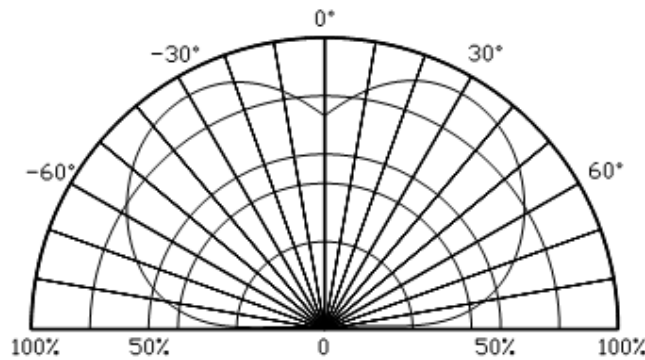

ChromeLED Corp. reserves the right to make changes at any time in order to supply the best product possible. The most current version of this document will always be available at: www.chromeled.com

PACKAGING SPECIFICATION

Feeding Direction

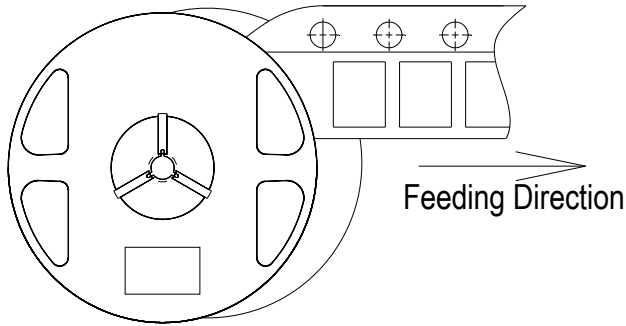

Dimensions of Reel (Unit: mm)

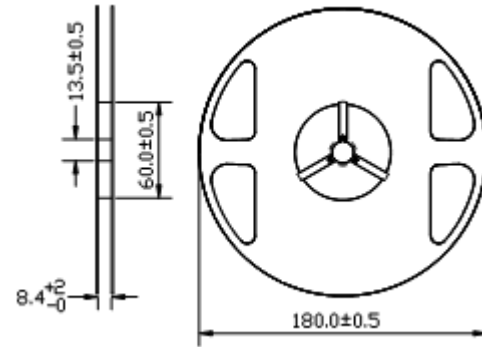

Dimensions of Tape (Unit: mm)

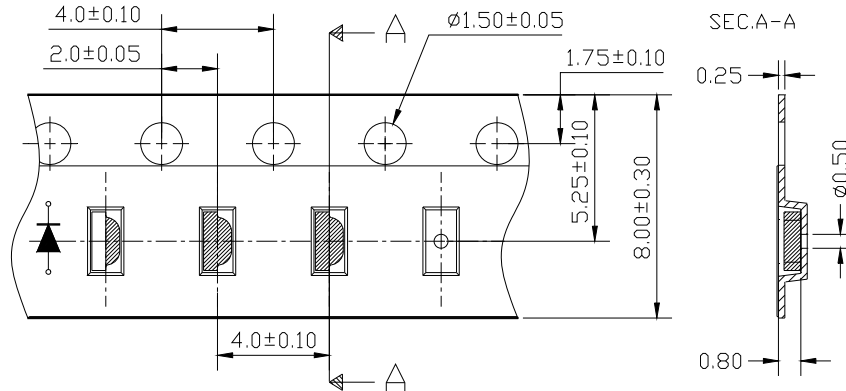

Arrangement of Tape

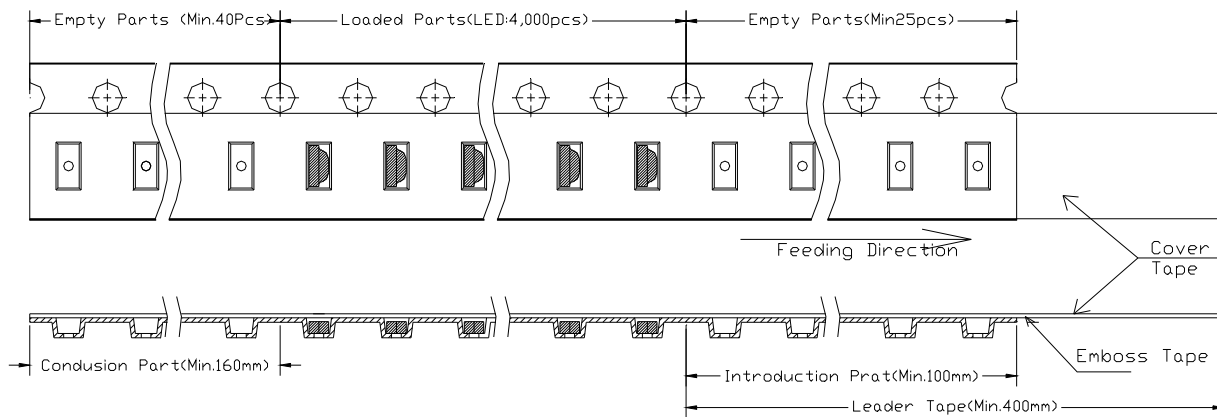

- Empty component pockets are sealed with top cover tape
- The maximum number of missing lamps is two
- The cathode is oriented towards the tape sprocket hole
- 4,000 pcs/Reel



ChromeLED Corp. reserves the right to make changes at any time in order to supply the best product possible. The most current version of this document will always be available at: www.chromeled.com

SOLDERING CONDITIONS

REFLOW PROFILE

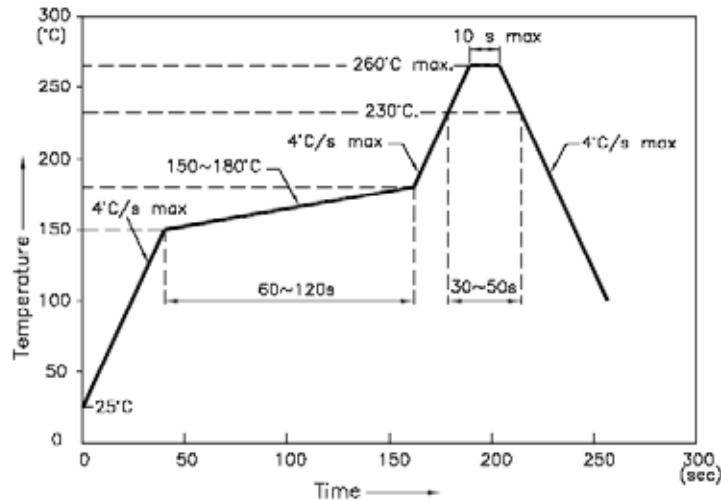

1. We recommend the reflow temperature 245°C ($\pm 5^\circ\text{C}$). The maximum soldering temperature should be limited to 260°C.
 2. Do not cause stress to the epoxy resin while it is exposed to high temperature.
 3. Number of reflow process should be 2 times or less.
- Soldering Iron
 - Basic spec is $\leq 5\text{sec}$ when 260°C. If temperature is higher, time should be shorter ($+10^\circ\text{C} \rightarrow -1\text{sec}$). Power dissipation of iron should be smaller than 20W and temperature should be controllable. Surface temperature of the device should be under 230°C.
 - Rework
 1. Customer must finish rework within 5 sec under 260°C.
 2. The head of iron cannot touch copper foil.
 3. Twin-head type is preferred.

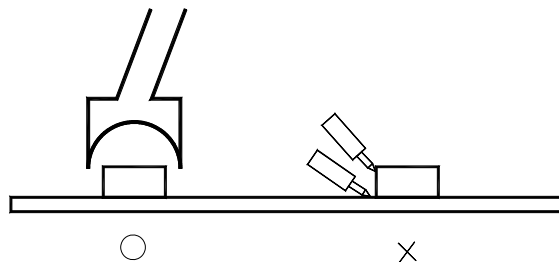

ChromeLED Corp. reserves the right to make changes at any time in order to supply the best product possible. The most current version of this document will always be available at: www.chromeled.com