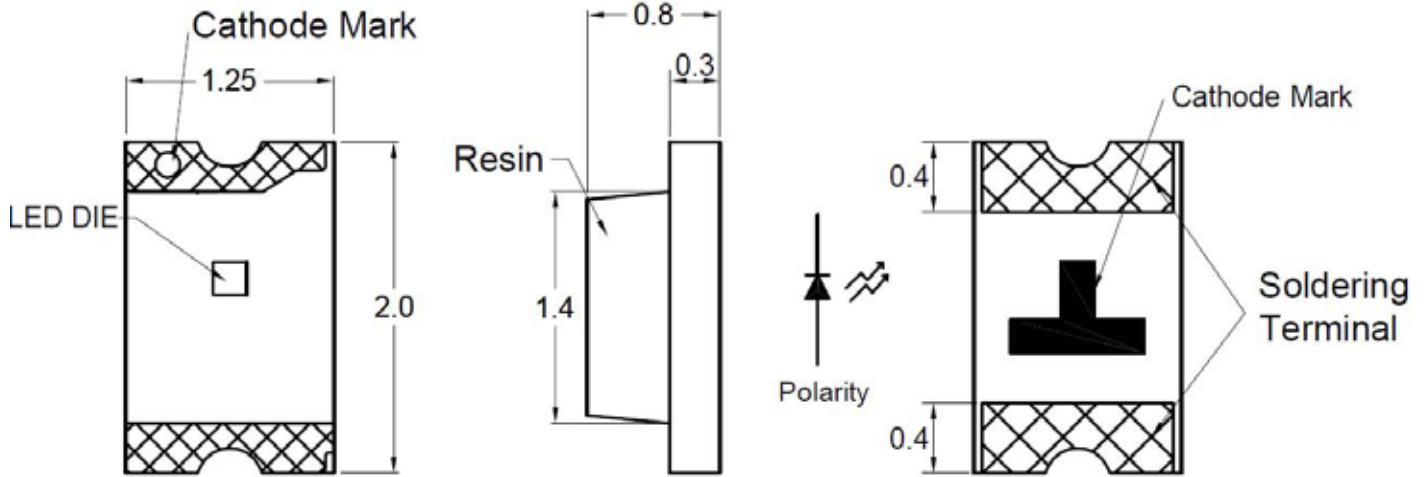
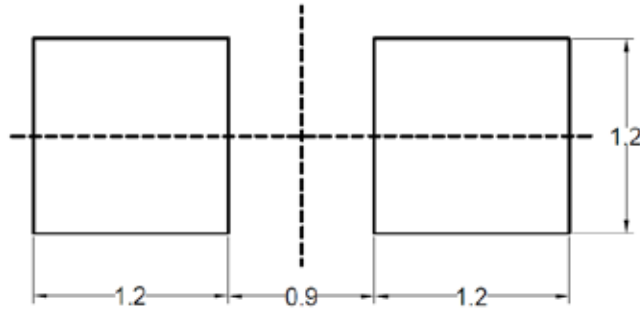

**SPECIFICATION** **CS85BIR850C**
**PACKAGE OUTLINES**

**Recommended Solder Pad**

**Notes:**

1. All dimensions are in millimeters (inches).
2. Tolerance is  $\pm 0.25\text{mm}$  (0.01") unless otherwise noted.
3. Specifications are subject to change without notice.

Part Number	Chip Material	Color of Emission	Lens Type	Viewing Angle
CS85BIR850C	GaAlAs	Infrared	Water Clear	140°



ChromeLED Corp. reserves the right to make changes at any time in order to supply the best product possible. The most current version of this document will always be available at: [www.chromeled.com](http://www.chromeled.com)

**ABSOLUTE MAXIMUM RATINGS**
**(TA=25°C)**

Parameter	Symbol	Max Rating	Unit
Forward Current	I <sub>F</sub>	50	mA
Reverse Current @ 5V	I <sub>R</sub>	5	μA
Power Dissipation	P <sub>d</sub>	100	mW
Operating Temperature Range	T <sub>OP</sub>	-40~+85	°C
Storage Temperature Range	T <sub>STG</sub>	-40~+85	°C
Peak Pulsing Current (1/10 duty f = 10KHz)	I <sub>FP</sub>	1	A
Soldering Temperature	T <sub>SOL</sub>	Max 260°C for 5 sec Max	

**OPTICAL-ELECTRICAL CHARACTERISTICS**
**(TA=25°C)**

Parameter	Symbol	Test Condition	Value			Unit
			Min	Typ	Max	
Radiant Intensity	I <sub>v</sub>	I <sub>F</sub> = 50mA	3.2	6.0	-	mW/sr
Forward Voltage	V <sub>F</sub>	I <sub>F</sub> = 50mA	-	1.7	1.9	V
Reverse Leakage Current	I <sub>R</sub>	V <sub>R</sub> = 5V	-	-	100	μA
Viewing Angle at 50% I <sub>v</sub>	2θ <sub>1/2</sub>	I <sub>F</sub> = 50mA	-	140	-	Deg
Peak Wavelength	λ <sub>P</sub>	I <sub>F</sub> = 50mA	-	850	-	nm
Dominant Wavelength	λ <sub>D</sub>	I <sub>F</sub> = 50mA	-	860	-	nm

\*Tolerance of viewing angle: -10 / +5 deg.



ChromeLED Corp. reserves the right to make changes at any time in order to supply the best product possible. The most current version of this document will always be available at: [www.chromeled.com](http://www.chromeled.com)

## OPTICAL CHARACTERISTIC CURVES

Fig.1 Forward Current vs. Forward Voltage

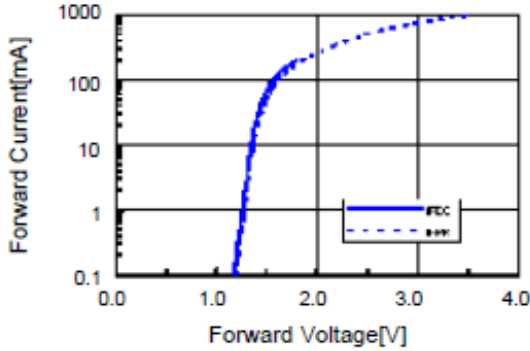

Fig.2 Relative Radiant Power vs. Wavelength

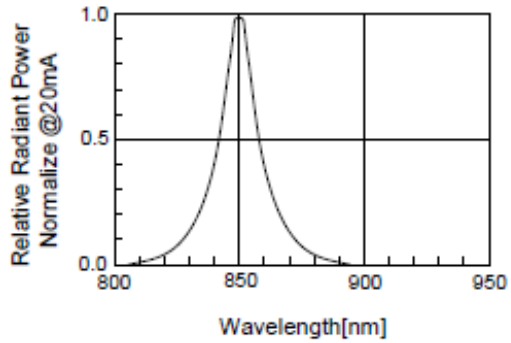

Fig.3 Relative Radiant Power vs. Forward DC Current

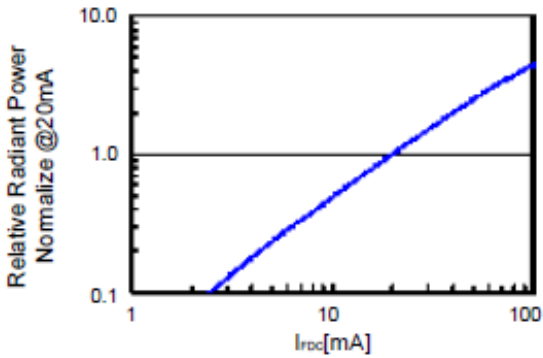

Fig.4 Relative Radiant Power vs. Forward Peak Current

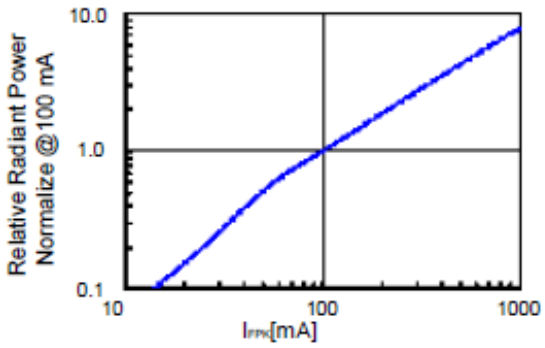

Fig.5 Forward DC Voltage vs. Temperature

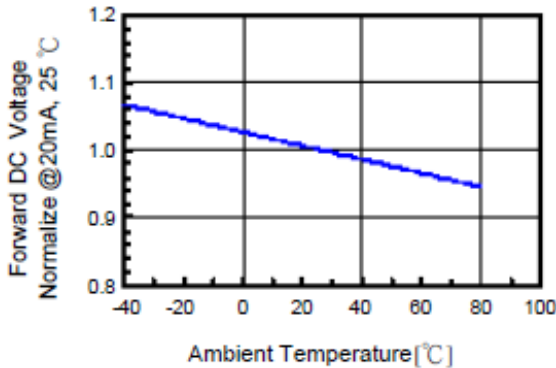

Fig.6 Relative Radiant Power vs. Temperature

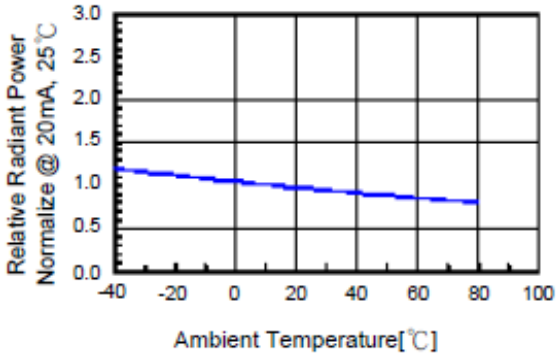
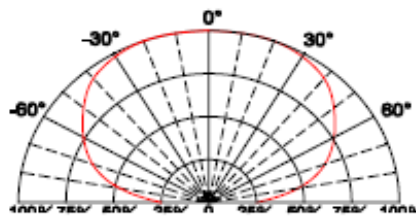
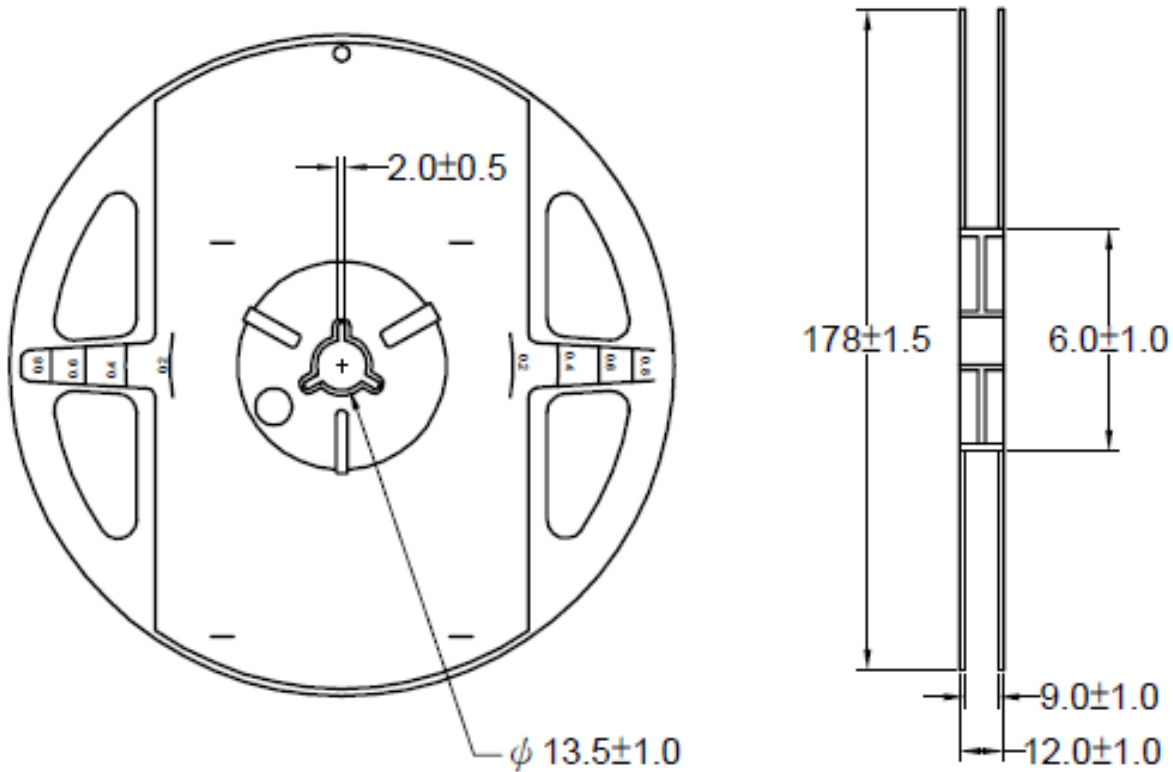
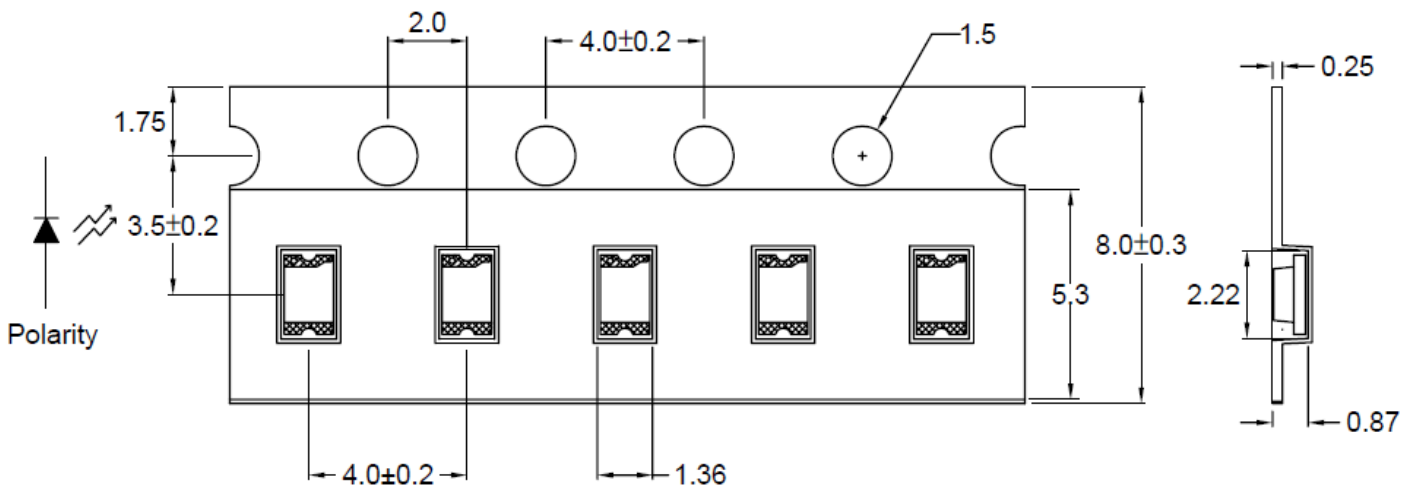

Fig.7 Directive Radiation



ChromeLED Corp. reserves the right to make changes at any time in order to supply the best product possible. The most current version of this document will always be available at: [www.chromeled.com](http://www.chromeled.com)

**PACKAGING SPECIFICATION**
**REEL DIMENSIONS**

**DIMENSIONS OF TAPE (UNIT: MM)**

**Notes:**

1. Empty component pockets are sealed with top cover tape;
2. The maximum number of missing lamps is two;
3. The cathode is oriented towards the tape sprocket hole.
4. 4,000pcs/Reel



ChromeLED Corp. reserves the right to make changes at any time in order to supply the best product possible. The most current version of this document will always be available at: [www.chromeled.com](http://www.chromeled.com)

# SOLDERING CONDITIONS

## RECOMMENDED Sn-PB IR-Reflow Soldering Profile

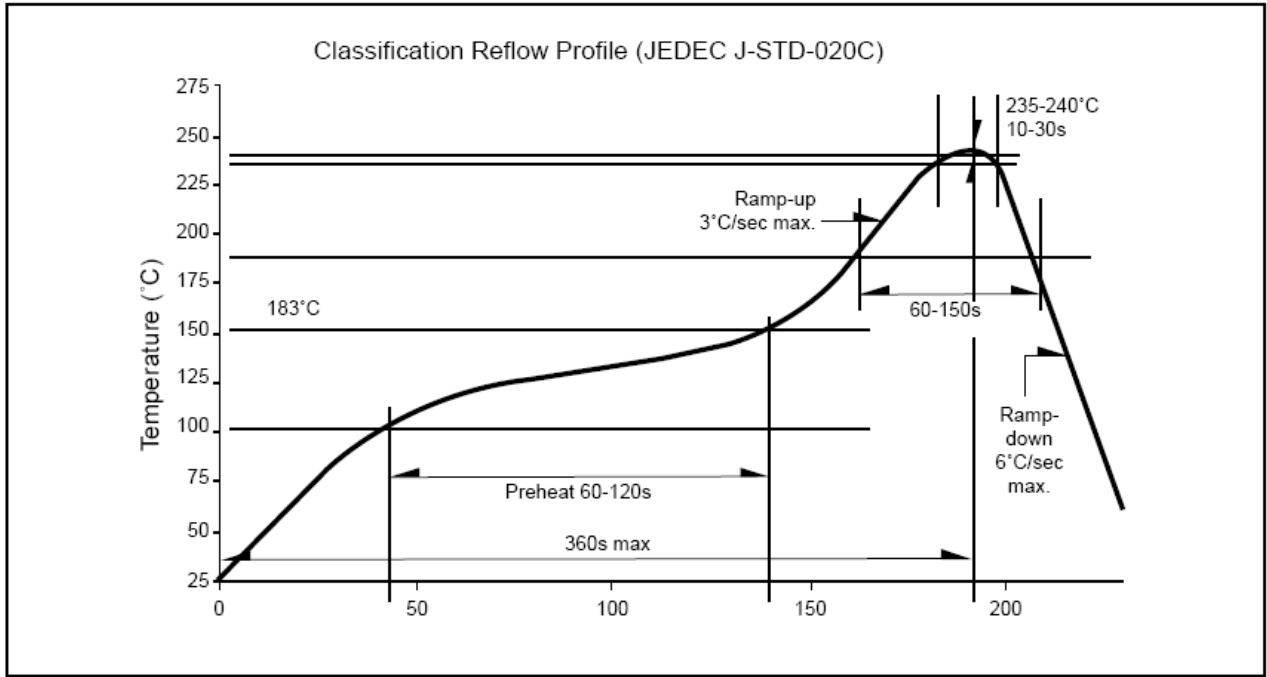

## RECOMMENDED Pb-Free Soldering Profile

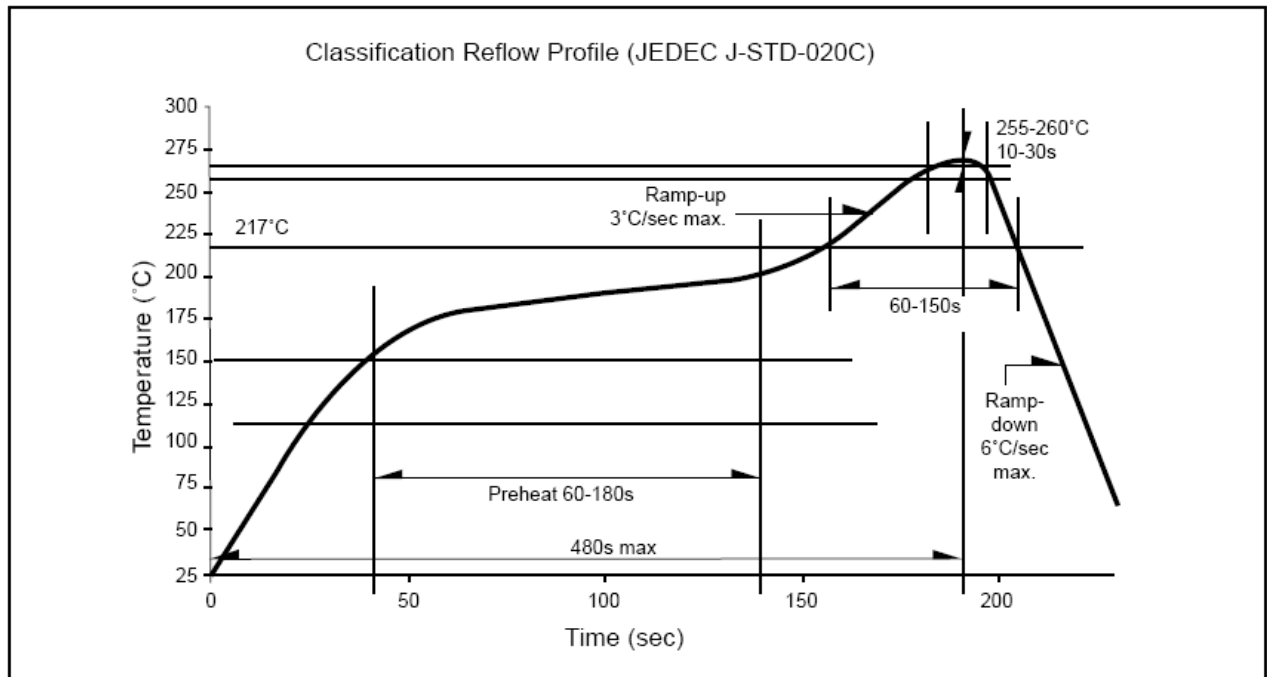

ChromeLED Corp. reserves the right to make changes at any time in order to supply the best product possible. The most current version of this document will always be available at: [www.chromeled.com](http://www.chromeled.com)