

SPECIFICATION **CS66B2R2GT2C**
PACKAGE OUTLINES

RECOMMEND PAD LAYOUT

- Notes:
1. All dimensions are in millimeters (inches).
 2. Tolerance is $\pm 0.25\text{mm}$ (0.01") unless otherwise noted.
 3. Specifications are subject to change without notice.

Part Number	Chip Material	Color of Emission	Lens Type	Viewing Angle
CS66B2G2GT2C	InGaAlP	Red	Water Clear	140°
	InGaN	True Green	Water Clear	140°
	InGaN	Blue	Water Clear	140°

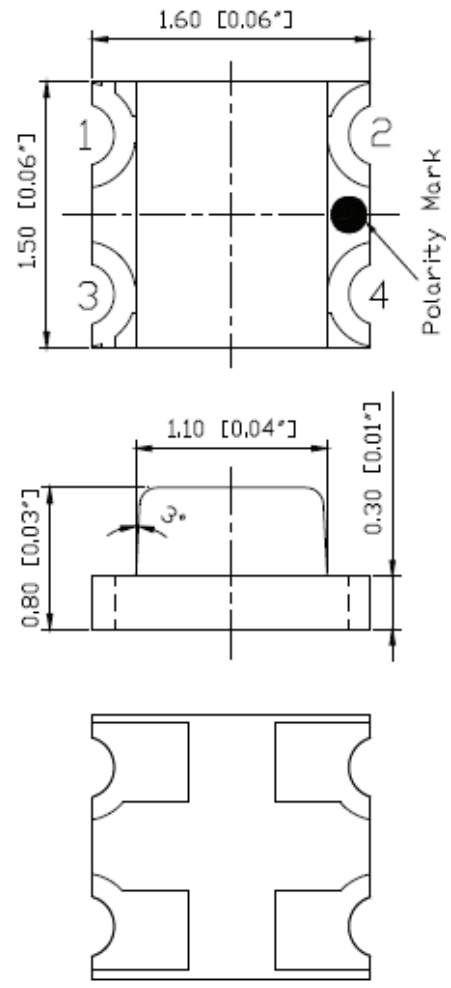
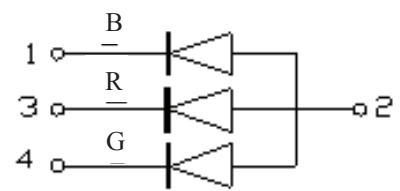
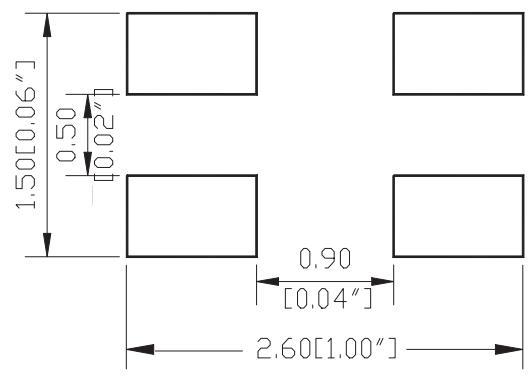

ChromeLED Corp. reserves the right to make changes at any time in order to supply the best product possible. The most current version of this document will always be available at: www.chromeled.com

ABSOLUTE MAXIMUM RATINGS
(TA=25°C)

Parameter	Symbol	Max Rating		Unit
		Blue/ Green	Red	
Forward Current	IF	30	30	mA
Reverse Voltage	VR	5	5	V
Power Dissipation	Pd	111	75	mW
Operating Temperature Range	TOP	-40~+85		°C
Storage Temperature Range	TSTG	-40~+85		°C
Peak Pulsing Current (tp ≤ 10 μs, duty cycle = 0.005)	IFP	125		mA

OPTICAL-ELECTRICAL CHARACTERISTICS
(TA=25°C)

Parameter	Symbol	Test Condition	Color	Value			Unit
				Min	Typ	Max	
Luminous Intensity	Iv	IF = 20mA	Red	80	150	-	mcd
			Green	250	440	-	
			Blue	40	65	-	
Forward Voltage	VF	IF = 20mA	Red	-	2.0	2.5	V
			Green	-	3.1	3.7	
			Blue	-	3.1	3.7	
Viewing Angle at 50% Iv	2θ1/2	IF = 20mA	-	-	140	-	Deg
Dominant Wavelength	λD	IF = 20mA	Red	615	620	630	nm
			Green	520	525	530	
			Blue	465	470	475	

*Tolerance of viewing angle: -10 / +5 deg.

*Tolerance of forward voltage is -/+ 0.05V

*Tolerance of luminous intensity -/+ 1nm



ChromeLED Corp. reserves the right to make changes at any time in order to supply the best product possible. The most current version of this document will always be available at: www.chromeled.com

TYPICAL ELECTRO-OPTICAL CHARACTERISTIC CURVES (RED)

Relative Intensity vs. Wavelength

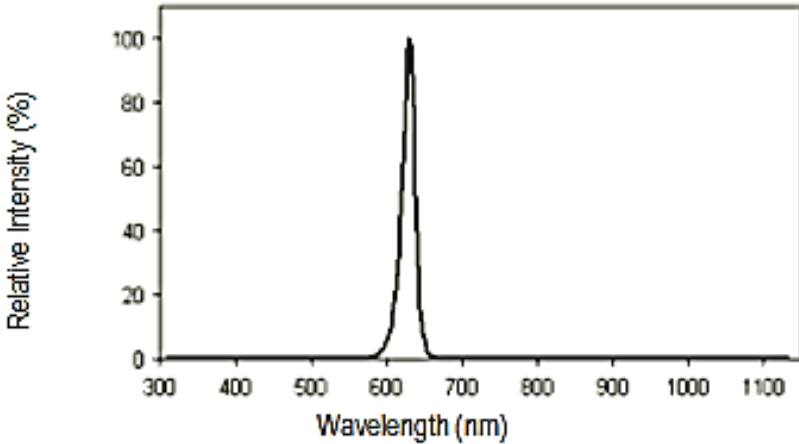

Forward Current vs. Forward Voltage

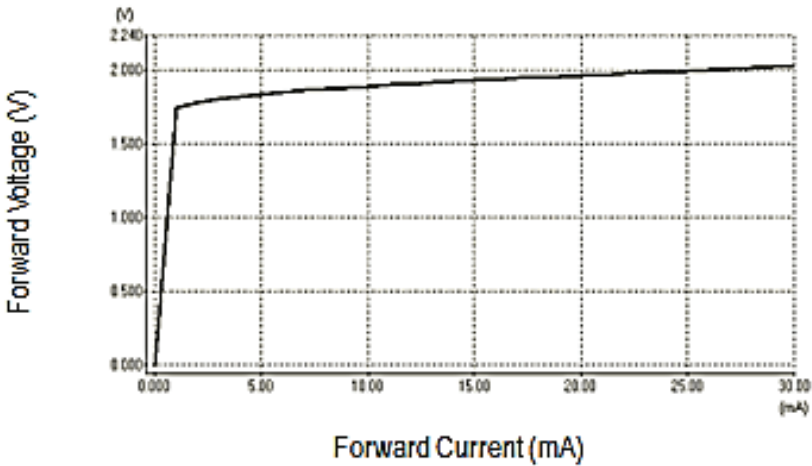

Directive Characteristics

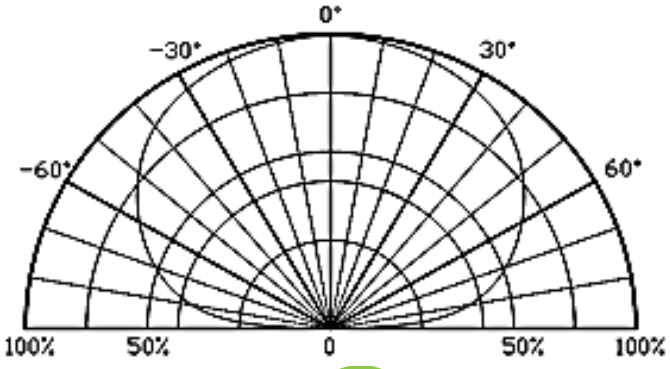

ChromeLED Corp. reserves the right to make changes at any time in order to supply the best product possible. The most current version of this document will always be available at: www.chromeled.com

TYPICAL ELECTRO-OPTICAL CHARACTERISTIC CURVES (GREEN)

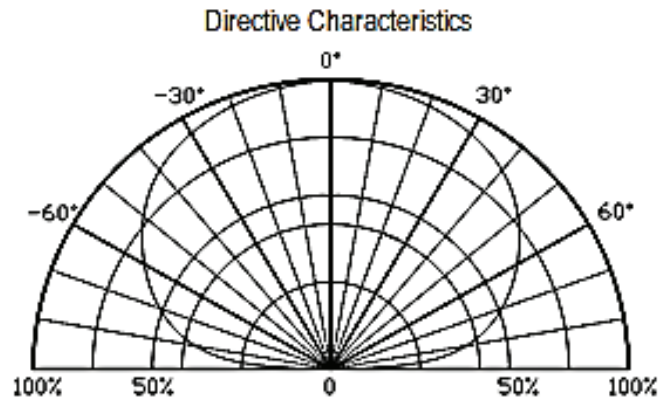
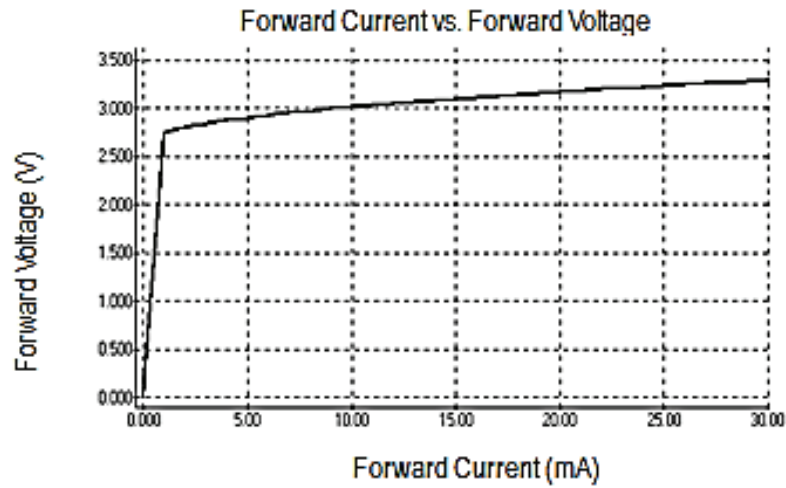
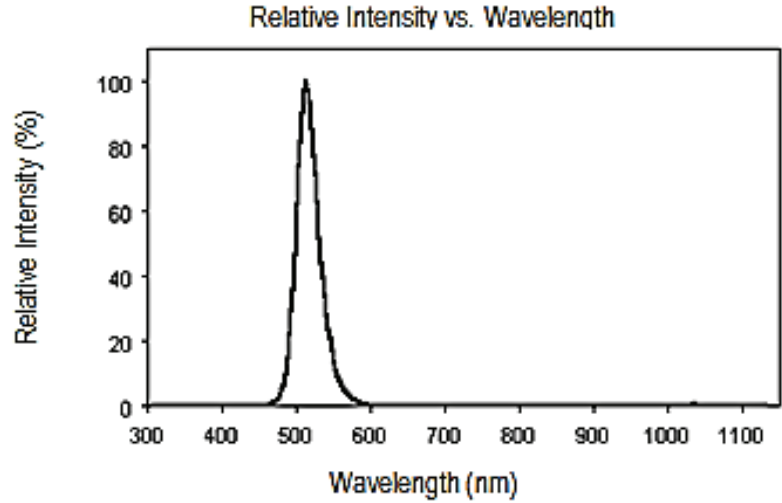

ChromeLED Corp. reserves the right to make changes at any time in order to supply the best product possible. The most current version of this document will always be available at: www.chromeled.com

TYPICAL ELECTRO-OPTICAL CHARACTERISTIC CURVES (BLUE)

Relative Intensity vs. Wavelength

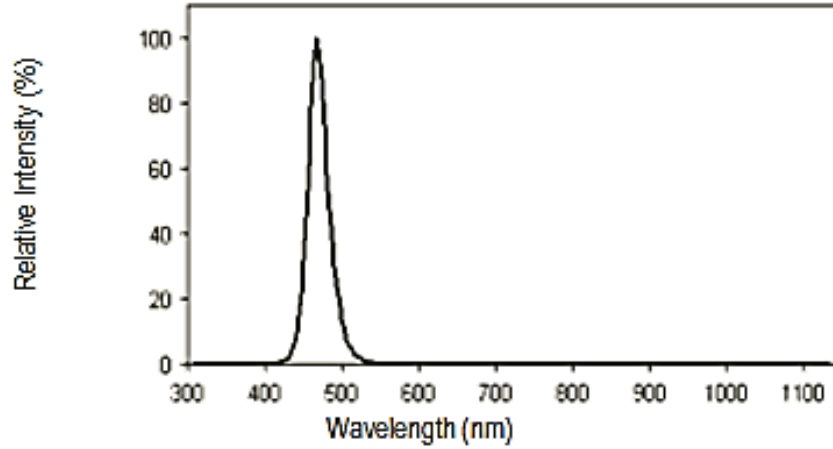

Forward Current vs. Forward Voltage

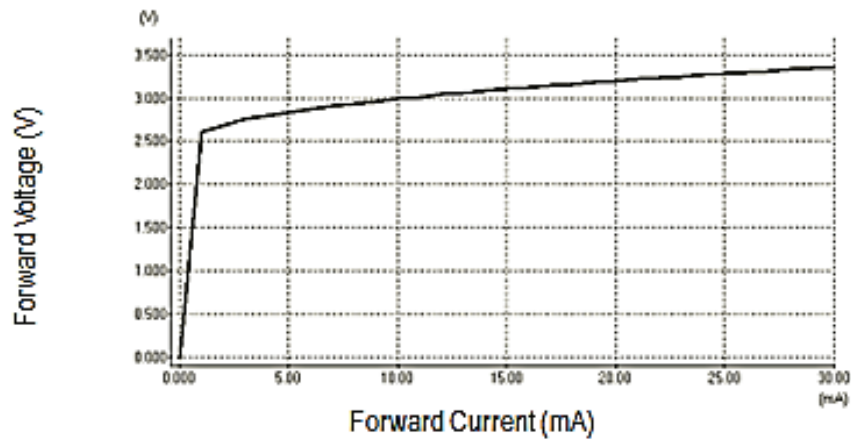

Directive Characteristics

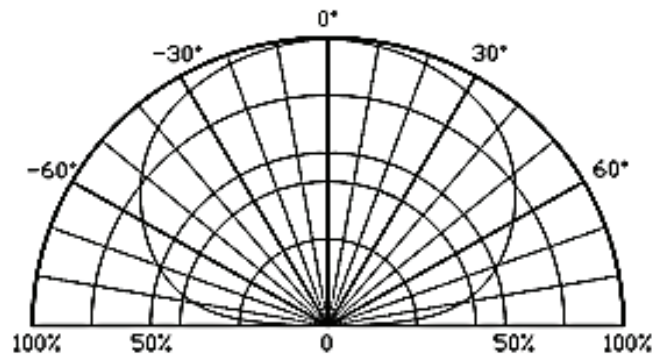

ChromeLED Corp. reserves the right to make changes at any time in order to supply the best product possible. The most current version of this document will always be available at: www.chromeled.com

SOLDERING CONDITIONS

REFLOW PROFILE

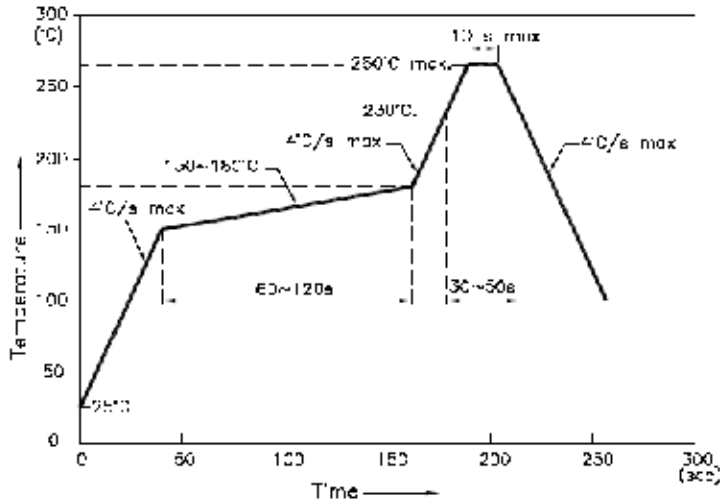

1. We recommend the reflow temperature 245°C (±5°C).the maximum soldering temperature should be limited to 260°C.
2. Don't cause stress to the epoxy resin while it is exposed to high temperature.
3. Number of reflow process shall be 2 times or less.
 - Soldering iron
 - Basic spec is ≤ 5sec when 260°C. If temperature is higher, time should be shorter
 - (+10°C → -1sec).Power dissipation of iron should be smaller than 20W, and temperatures should be controllable. Surface temperature of the device should be under 230°C.

Rework

1. Customer must finish rework within 5 sec under 260°C.
2. The head of iron cannot touch copper foil.
3. Twin-head type is preferred.

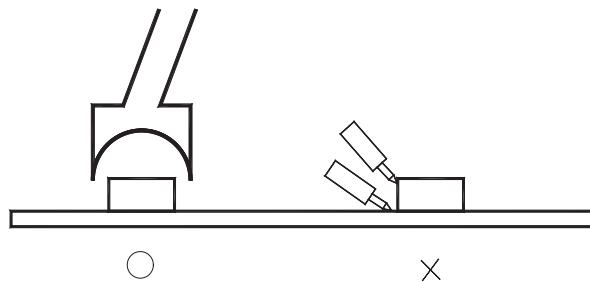

ChromeLED Corp. reserves the right to make changes at any time in order to supply the best product possible. The most current version of this document will always be available at: www.chromeled.com

REEL PACKAGING

- Feeding Direction

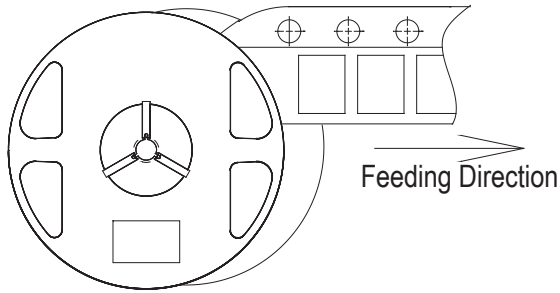

- Dimensions of Reel (Unit: mm)

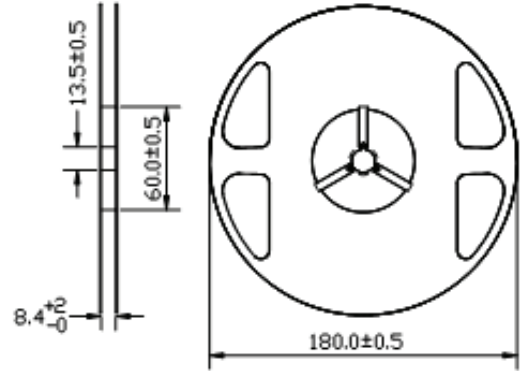

- Dimensions of Tape (Unit: mm)

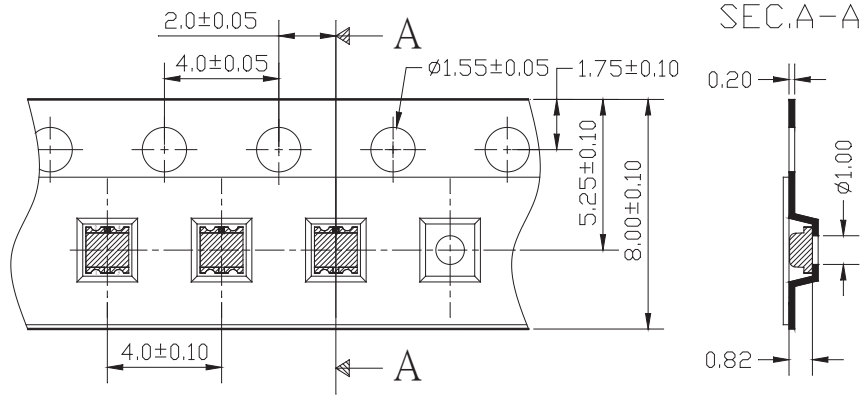

- Arrangement of Tape

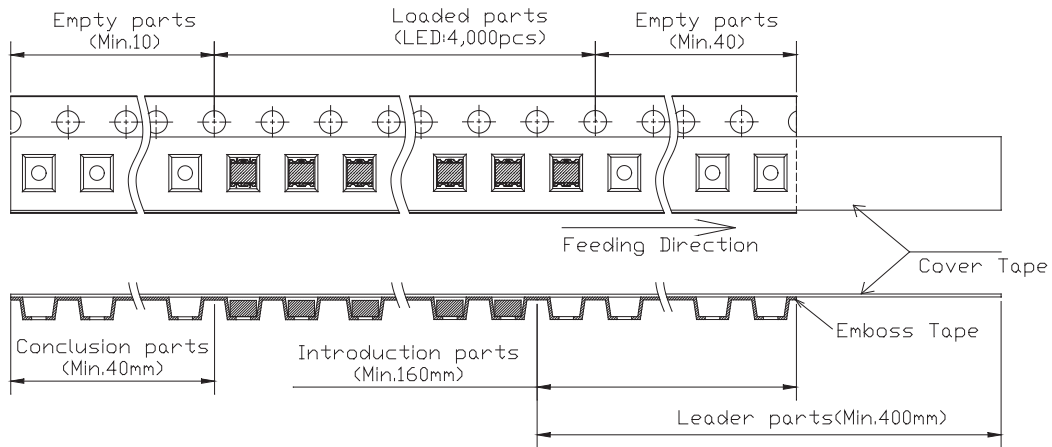

Notes:

1. Empty component pockets are sealed with top cover tape;
2. The maximum number of missing lamps is two;
3. 4,000pcs/Reel



ChromeLED Corp. reserves the right to make changes at any time in order to supply the best product possible. The most current version of this document will always be available at: www.chromeled.com