

SPECIFICATIONS **CS121R2G2C**

OUTLINES DIMENSIONS

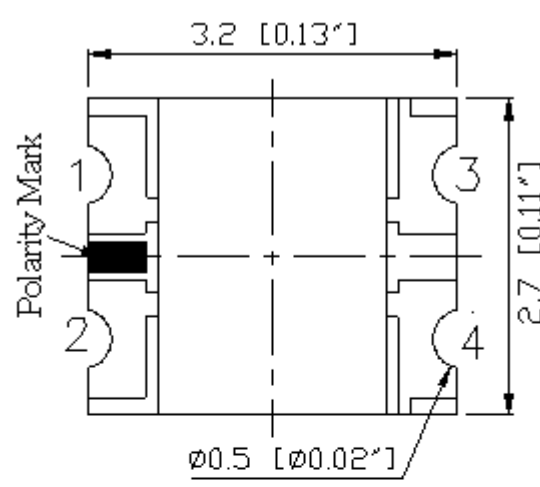

RECOMMENDED PAD LAYOUT

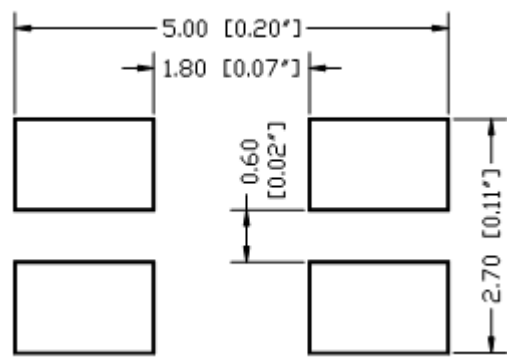

ITEM		MATERIALS
Resin (mold)		Epoxy
Lens color		Water Transparent
Dice	Red	AlGaInP/GaAs
	Green	AlGaInP

Notes:
 1. All Dimensions are in millimeters (inches).
 2. Tolerance is $\pm 0.25\text{mm}$ (0.01") unless otherwise noted.
 3. Specifications are subject to change without notice.

Part Number	Chip Material	Color of Emission	Lens Type	Viewing Angle
CS121R2G2C	InGaAlP	Red/Green	Water Clear	140°



ChromeLED Corp. reserves the right to make changes at any time in order to supply the best product possible. The most current version of this document will always be available at: www.chromeled.com

ABSOLUTE MAXIMUM RATINGS
(TA=25°C)

Parameter	Symbol	Color	Max Rating	Unit
Power Dissipation	PD	Red	75	mW
		Green		
Pulse Current Forward Current	IFP	Red	125	mA
		Green		
Continuous Forward Current	IF	Red	30	mA
		Green		
Reverse Voltage	VR	5		V
Operating Temperature Range	TOPR	-40~+85		°C
Storage Temperature Range	TSTG	-40~+85		°C

IFP = Pulse Width ≤ 10 ms, Duty Ratio ≤ 1/8. Soldering Condition: 260 °C/ 5sec

OPTICAL-ELECTRICAL CHARACTERISTICS
(TA=25°C)

Parameter	Symbol	Test Condition	Color	Value			Unit
				Min	Typ	Max	
Luminous Intensity	IV	IF = 20mA	Red	40	65	-	mcd
			Green	40	60	-	
Forward Voltage	VF	IF = 20mA	Red	-	2.1	2.5	V
			Green	-	2.0	2.5	
Reverse Leakage Current	IR	VR = 5V	Red	-	-	10	µA
			Green	-	-	10	
Viewing Angle	2θ1/2	IF = 10mA	Red	-	140	-	deg
			Green	-	140	-	
Dominant Wavelength	λD	IF = 20mA	Red	630	640	650	nm
			Green	565	570	576	

*Tolerance of viewing angle: -10 / +5 deg.



ChromeLED Corp. reserves the right to make changes at any time in order to supply the best product possible. The most current version of this document will always be available at: www.chromeled.com

OPTICAL CHARACTERISTIC CURVES (RED)

Relative Intensity vs. Wavelength

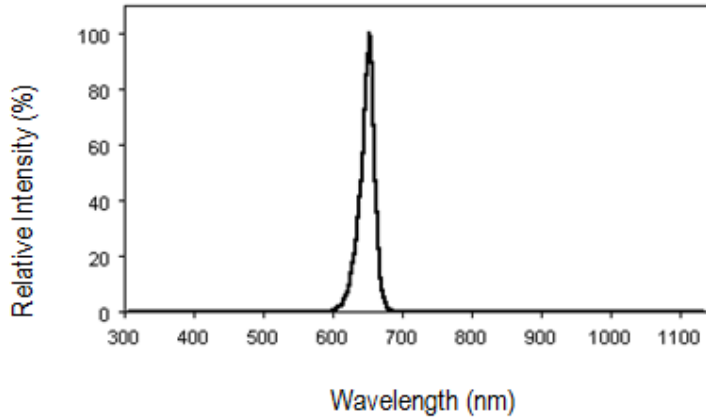

Forward Current vs. Forward Voltage

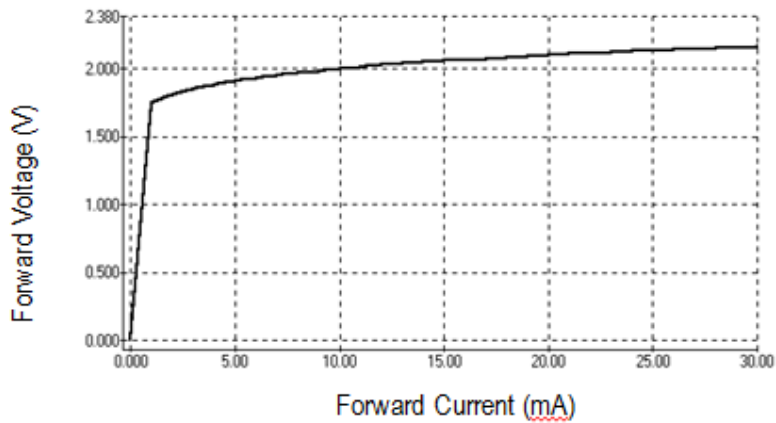

Directive Characteristics

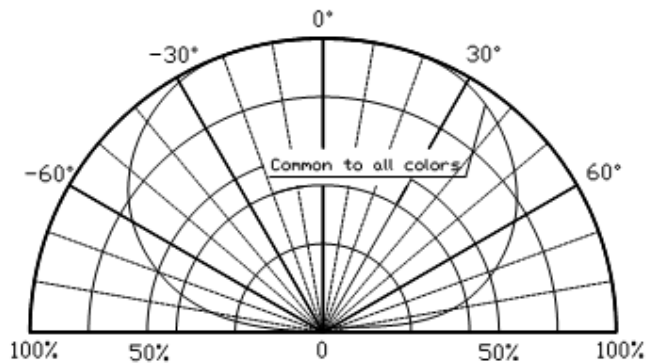

ChromeLED Corp. reserves the right to make changes at any time in order to supply the best product possible. The most current version of this document will always be available at: www.chromeled.com

OPTICAL CHARACTERISTIC CURVES (GREEN)

Relative Intensity vs. Wavelength

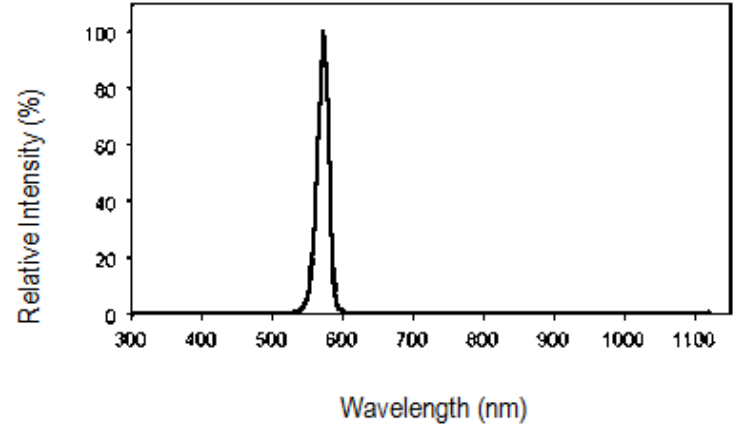

Forward Current vs. Forward Voltage

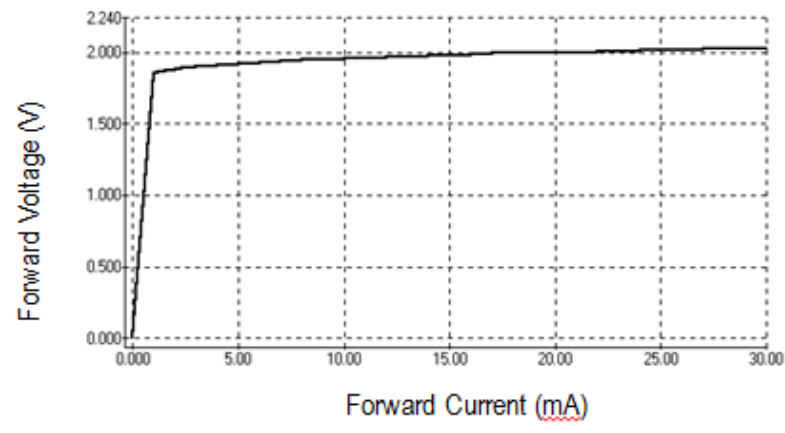

Directive Characteristics

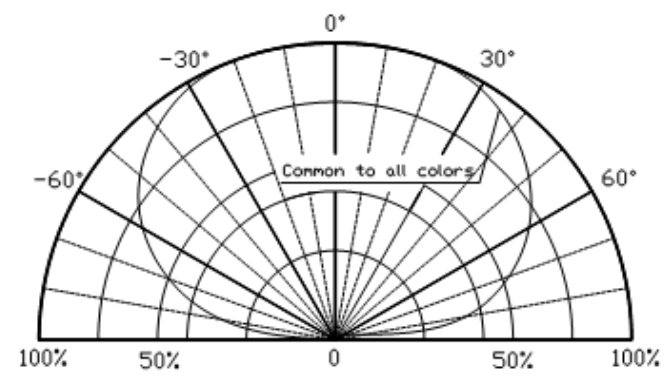

ChromeLED Corp. reserves the right to make changes at any time in order to supply the best product possible. The most current version of this document will always be available at: www.chromeled.com

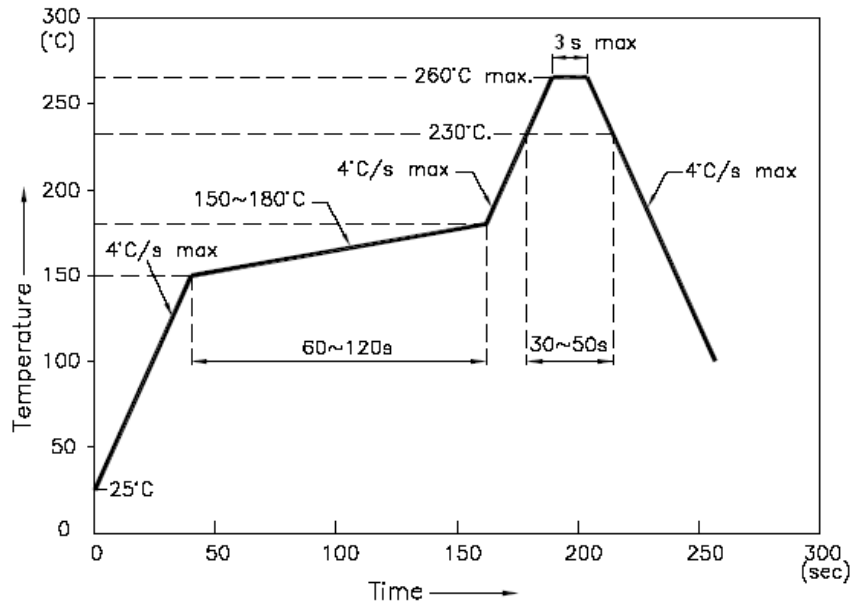
SOLDERING CONDITIONS – LAMP TYPE LED
REFLOW PROFILE
Reflow Temp/Time

Notes:

1. We recommend the reflow temperature 245°C ($\pm 5^\circ\text{C}$). The maximum soldering temperature should be limited to 260°C.
2. Don't cause stress to the epoxy resin while it is exposed to high temperature.
3. Number of reflow process should be 2 times or less.

Soldering Iron

Basic spec is ≤ 5 sec when 260°C. If temperature is higher, time should be shorter ($\pm 10^\circ\text{C} \rightarrow -1\text{sec}$). Power dissipation of iron should be smaller than 20W and temperature should be controllable. Surface temperature of the device should be under 230°C.



ChromeLED Corp. reserves the right to make changes at any time in order to supply the best product possible. The most current version of this document will always be available at: www.chromeled.com

PACKAGING SPECIFICATIONS

Feeding Direction

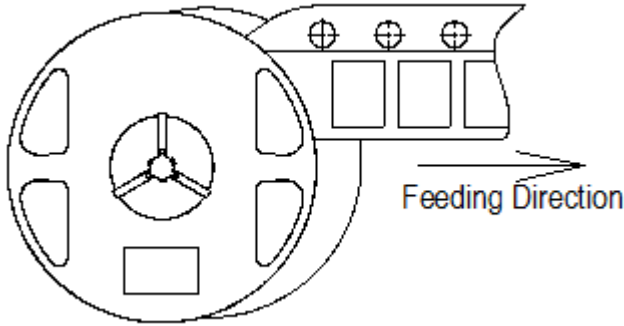

Dimensions of Reel (Unit: mm)

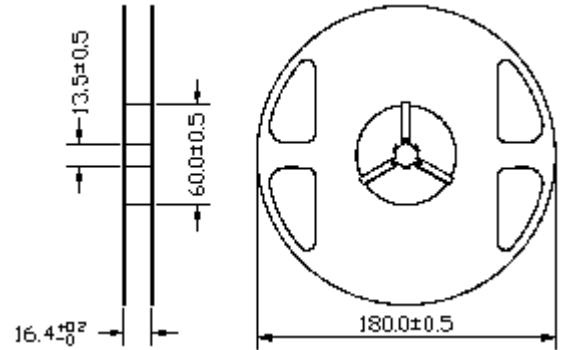

Dimensions of Tape (Unit: mm)

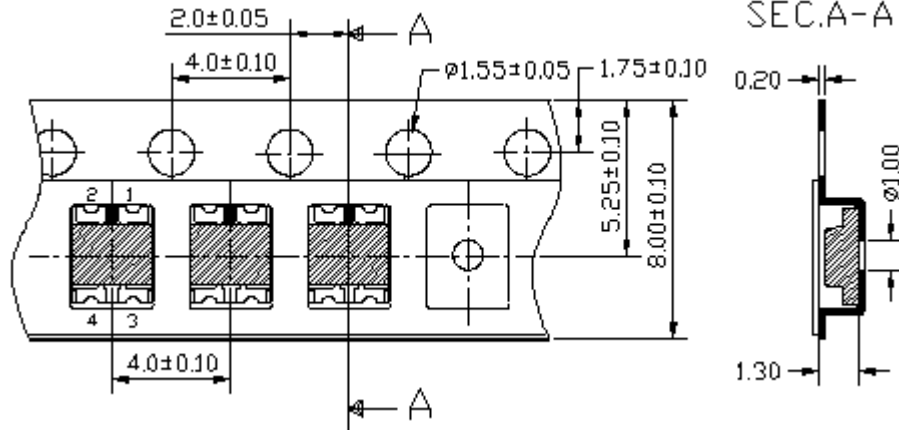

Arrangement of Tape

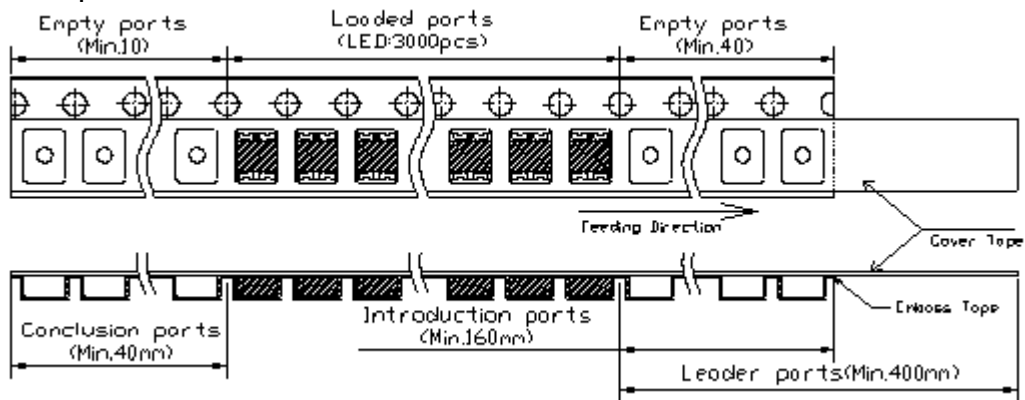

Notes:

1. Empty component pockets are sealed with top cover tape;
2. The maximum number of missing lamp is two;
3. The cathode is oriented towards the tape sprocket hole;
4. 3,000 pcs/Reel



ChromeLED Corp. reserves the right to make changes at any time in order to supply the best product possible. The most current version of this document will always be available at: www.chromeled.com