

SPECIFICATION **CLV54SR2DS-110**

OUTLINES DIMENSIONS / Lamps with Standoffs

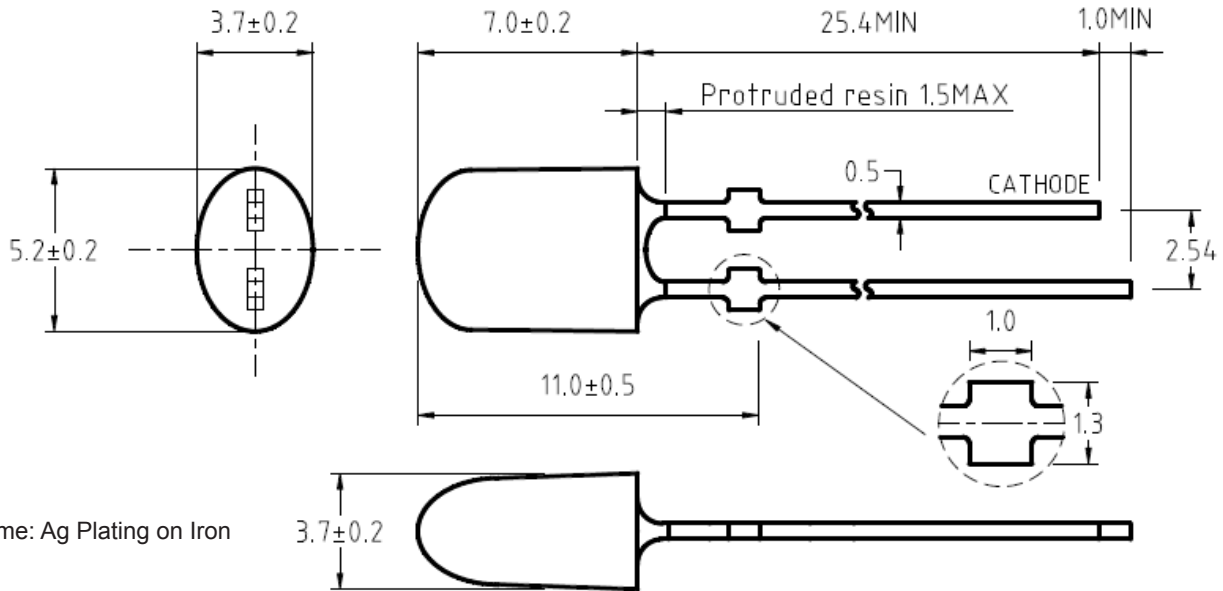

Lead Frame: Ag Plating on Iron

- Notes:
1. All Dimensions are in millimeters (inches).
 2. Tolerance is $\pm 0.25\text{mm}$ ($0.01''$) unless otherwise noted.
 3. Specifications are subject to change without notice.

Luminous Intensity Bin Table		
IF=20mA		
Rank Name	Min (mcd)	Max (mcd)
N	680	880
P	880	1150
Q	1150	1500
R	1500	1900

* Tolerance for each bin limit is $\pm 15\%$

Color Bin Table		
IF=20mA		
Rank Name	Min (mcd)	Max (mcd)
1	615	620
2	620	625
3	625	630
4	630	635

* Tolerance for each bin limit is $\pm 1\text{nm}$

Part Number	Chip Material	Color of Emission	Lens Type	Viewing Angle
CLV54SR2DS-110	AllnGaP	Red	Epoxy Resin	110/40°



ChromeLED Corp. reserves the right to make changes at any time in order to supply the best product possible. The most current version of this document will always be available at: www.chromeled.com

ABSOLUTE MAXIMUM RATINGS
(TA=25°C)

Parameter	Symbol	Max Rating	Unit
Power Dissipation	P_D	120	mW
Pulse Current Forward Current	I_{FP}	100	mA
Continuous Forward Current	I_F	50	mA
Reverse Voltage	V_R	5.0	V
Operating Temperature Range	T_{OPR}	-30 ~ +85	°C
Storage Temperature Range	T_{STG}	-40 ~ +100	°C

 I_{FP} = Pulse Width \leq 10 ms, Duty Ratio \leq 1/10. Soldering Condition: 260 °C/ 5sec

OPTICAL-ELECTRICAL CHARACTERISTICS
(TA=25°C)

Parameter	Symbol	Test Condition	Min	Typ	Max	Unit
Luminous Intensity	I_V	$I_F = 20\text{mA}$	680	900		mcd
Forward Voltage	V_F	$I_F = 20\text{mA}$		2.1	2.4	V
Reverse Leakage Current	I_R	$V_R = 5\text{V}$			50	μA
Viewing Angle	$2\theta_{1/2}$	$I_F = 20\text{mA}$		110/40°		deg.
Peak Wavelength	λ_P	$I_F = 20\text{mA}$		635		nm
Dominant Wavelength	λ_D	$I_F = 20\text{mA}$	615	625	635	nm
Spectral Line half-width	$\Delta\lambda$	$I_F = 20\text{mA}$		15		nm

*Tolerance of viewing angle: -10 / +5 deg.



 ChromeLED Corp. reserves the right to make changes at any time in order to supply the best product possible. The most current version of this document will always be available at: www.chromeled.com

OPTICAL CHARACTERISTIC CURVES

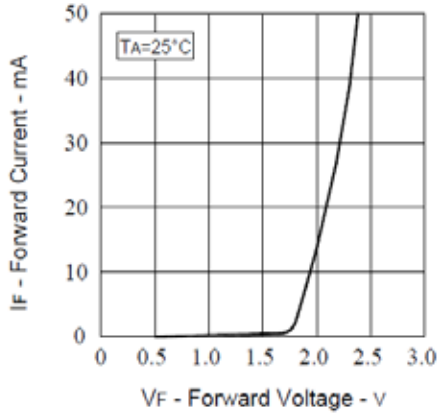
Forward Current vs. Forward Voltage

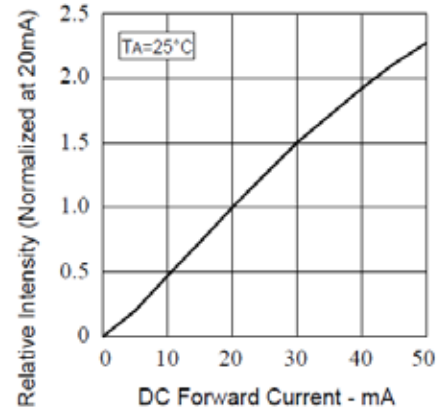

Relative Intensity vs. Forward Current



Forward Current vs. Ambient Temperature

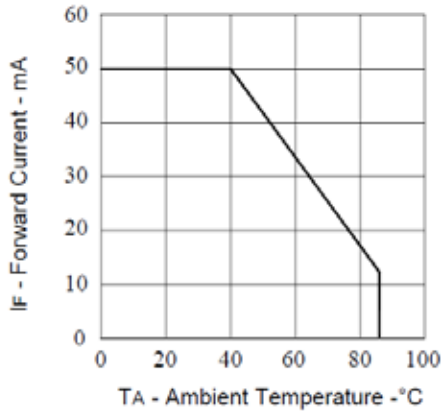

Relative Intensity vs. Wavelength

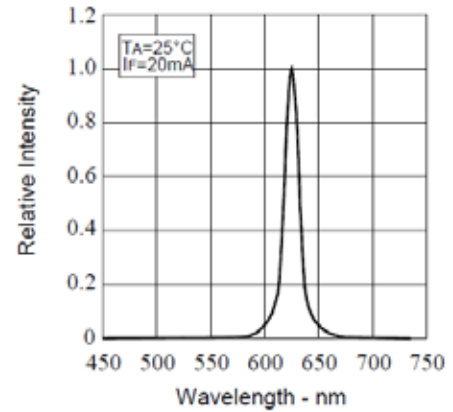

ChromeLED Corp. reserves the right to make changes at any time in order to supply the best product possible. The most current version of this document will always be available at: www.chromeled.com

SOLDERING CONDITIONS – LAMP TYPE LED

* Solder the LED no closer than 3mm from the base of the epoxy bulb. Soldering beyond the base of the tie bar is recommended.

* Recommended soldering conditions

Dip Soldering	
Pre-Heat	100 °C Max
Pre-Heat Time	60 Second Max
Solder Bath Temperature	260 °C Max
Dipping Time	5 Second Max
Dipping Position	No lower than 3mm from the base of the epoxy

Hand Soldering		
	3mm Series	Others
Temperature Soldering Time Position	300 °C Max 3 Second Max No closer than 3mm from the base of the epoxy	350 °C Max 3 Second Max No closer than 3mm from the base of the epoxy

* Do not apply any stress to the lead. Particularly when heated.

* The LED must not be repositioned after soldering.

* After soldering the LEDs, the epoxy bulb should be protected from mechanical shock or vibration until the LEDs return to room temperature.

* Direct soldering onto a PC board should be avoided. Mechanical stress to the resin may be caused by the PC board warping or from the clinching and cutting of the leadframes. When it is absolutely necessary, the LEDs may be mounted in this fashion, but, the user will assume responsibility for any problems. Direct soldering should only be done after testing has confirmed that no damage, such as wire bond failure or resin deterioration, will occur. LEDs should not be soldered directly to double sided PC boards because the heat will deteriorate the epoxy resin.

* When it is necessary to clamp the LEDs to prevent soldering failure, it is important to minimize the mechanical stress on the LEDs.

* Cut the LED leadframes at room temperature. Cutting the leadframes at high temperature may cause LED failure.



ChromeLED Corp. reserves the right to make changes at any time in order to supply the best product possible. The most current version of this document will always be available at: www.chromeled.com