

SPECIFICATION **CLT50R2GT2B2WCA**
PACKAGE OUTLINES
Description

- *Round Type Tri Color
- *T1-3/4 (5mm) Diameter
- *Lens Color: White Diffused
- *With Flange

Features

- *Emitting Color: R/G/B
- *High Luminous Intensity
- *Technology: InGaAlP/InGaN/InGaN
- *Peak Wavelength = 630/525/468nm

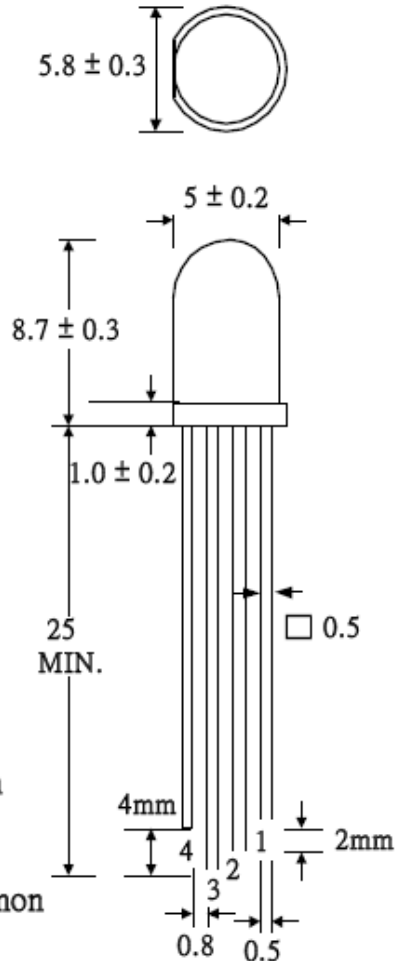

1. Green
2. Blue
3. Red
4. Common Anode

- Notes:
1. All dimensions are in millimeters (inches).
 2. Tolerance is $\pm 0.25\text{mm}$ (0.01") unless otherwise noted.
 3. Specifications are subject to change without notice.

Part Number	Chip Material	Color of Emission	Lens Type	Viewing Angle
CLT50R2GT2B2WCA	InGaAlP	Red	White Diffused	45°
	InGaN	Green		
	InGaN	Blue		



ChromeLED Corp. reserves the right to make changes at any time in order to supply the best product possible. The most current version of this document will always be available at: www.chromeled.com

ABSOLUTE MAXIMUM RATINGS
(TA=25°C)

Parameter	Symbol	Max Rating			Unit
		Red	Green	Blue	
Forward Current	I _F	50	30		mA
Reverse Current @ 5V	I _R	10	50		μA
Power Dissipation	P _d	120			mW
Operating Temperature Range	T _{OP}	-20~+85			°C
Storage Temperature Range	T _{STG}	-20~+85			°C
Peak Pulsing Current (1/10 duty f = 10KHz)	I _{FP}	100			mA
Soldering Temperature	T _{SOL}	Max 260°C for 5 sec Max			

OPTICAL-ELECTRICAL CHARACTERISTICS
(TA=25°C)

Parameter	Symbol	Test Condition	Color	Value			Unit
				Min	Typ	Max	
Luminous Intensity	I _v	I _F = 20mA	R	560	840	-	mcd
			G	1000	1500		
			B	200	300		
Forward Voltage	V _F	I _F = 20mA	R	-	2.3	2.4	V
			G	-	3.2	3.8	
			B	-	3.2	3.8	
Viewing Angle at 50% I _v	2θ _{1/2}	I _F = 20mA	-	-	45	-	Deg
Dominant Wavelength	λ _P	I _F = 20mA	R	-	625	-	nm
			G		520		
			B		470		

*Tolerance of viewing angle: -10 / +5 deg.



 ChromeLED Corp. reserves the right to make changes at any time in order to supply the best product possible. The most current version of this document will always be available at: www.chromeled.com

OPTICAL CHARACTERISTIC CURVES - RED

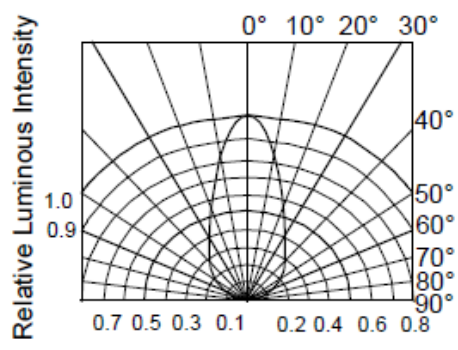
(RED)

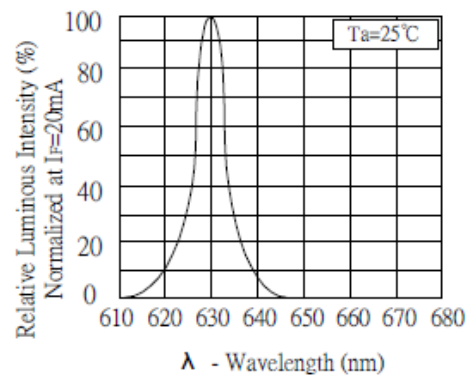

RADIATION DIAGRAM



RELATIVE LUMINOUS INTENSITY Vs. WAVELENGTH

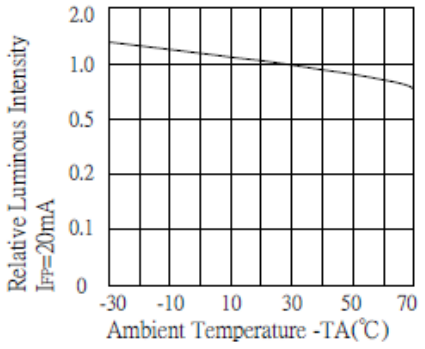

LUMINOUS INTENSITY Vs. AMBIENT TEMPERATURE

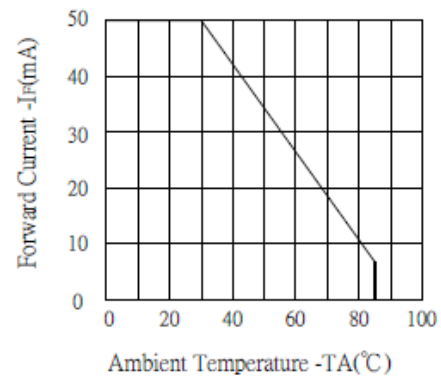

MAX FORWARD CURRENT Vs. AMBIENT TEMPERATURE

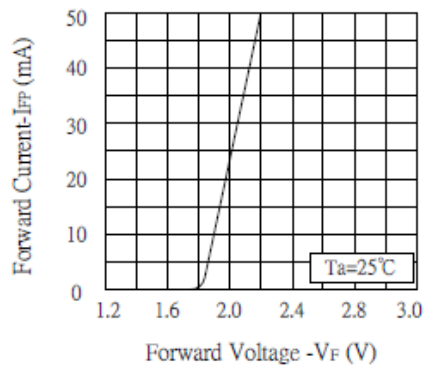

FORWARD CURRENT Vs. FORWARD VOLTAGE

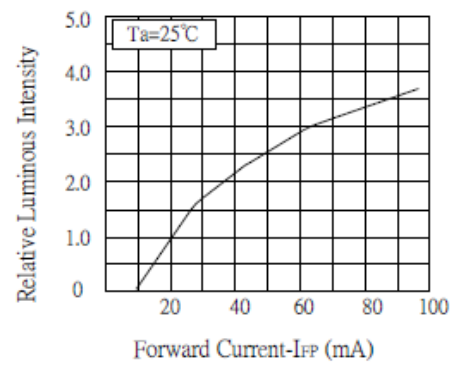

LUMINOUS INTENSITY Vs. FORWARD CURRENT



ChromeLED Corp. reserves the right to make changes at any time in order to supply the best product possible. The most current version of this document will always be available at: www.chromeled.com

OPTICAL CHARACTERISTIC CURVES - GREEN

(Green)

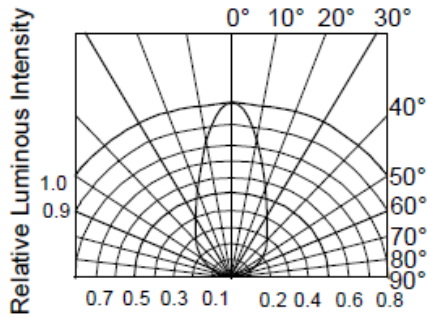

RADIATION DIAGRAM

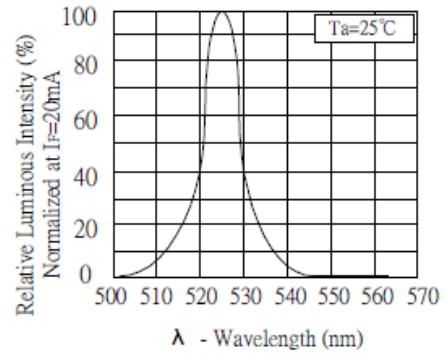

RELATIVE LUMINOUS INTENSITY Vs. WAVELENGTH

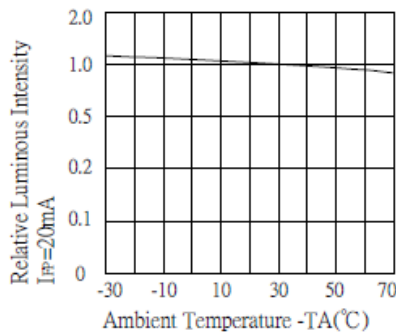

LUMINOUS INTENSITY Vs. AMBIENT TEMPERATURE

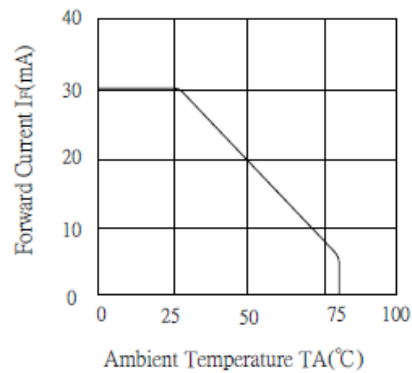

MAX FORWARD CURRENT Vs. AMBIENT TEMPERATURE

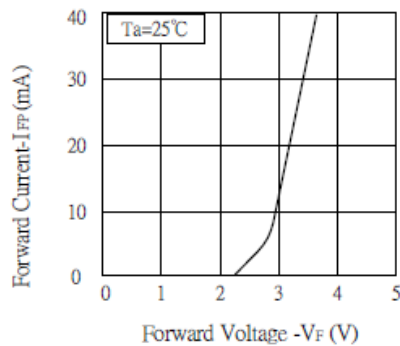

FORWARD CURRENT Vs. FORWARD VOLTAGE

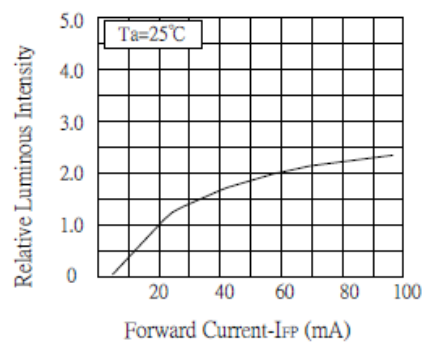

LUMINOUS INTENSITY Vs. FORWARD CURRENT



ChromeLED Corp. reserves the right to make changes at any time in order to supply the best product possible. The most current version of this document will always be available at: www.chromeled.com

OPTICAL CHARACTERISTIC CURVES - BLUE

(Blue)

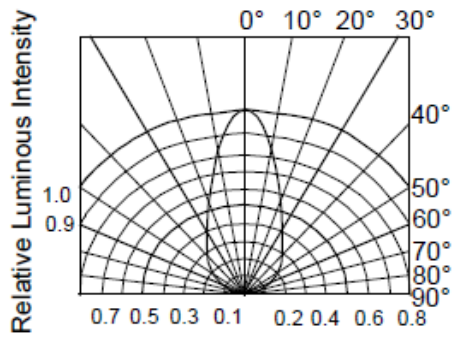

RADIATION DIAGRAM

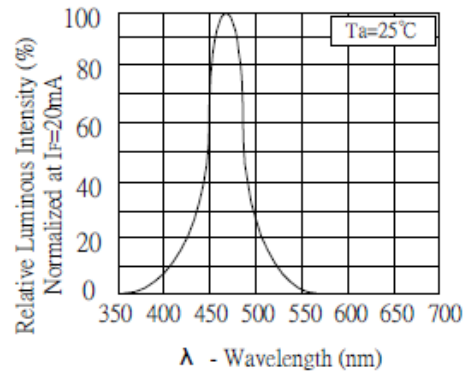

RELATIVE LUMINOUS INTENSITY Vs. WAVELENGTH

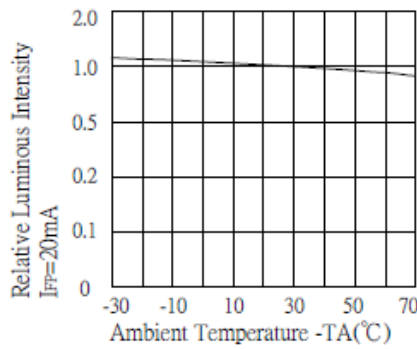

LUMINOUS INTENSITY Vs. AMBIENT TEMPERATURE

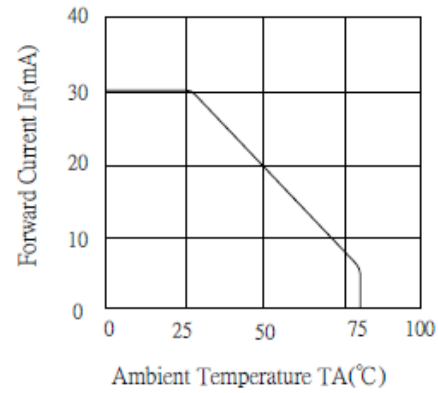

MAX FORWARD CURRENT Vs. AMBIENT TEMPERATURE

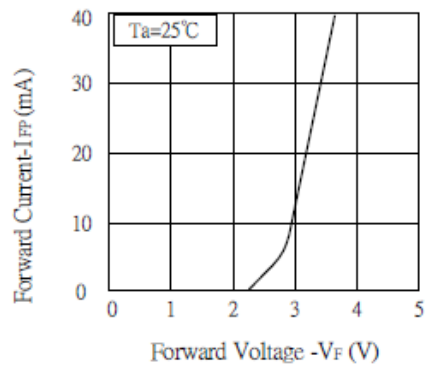

FORWARD CURRENT Vs. FORWARD VOLTAGE

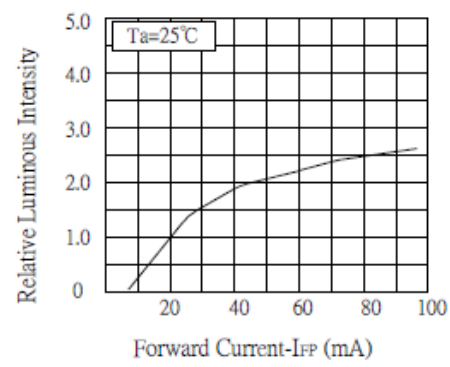

LUMINOUS INTENSITY Vs. FORWARD CURRENT



ChromeLED Corp. reserves the right to make changes at any time in order to supply the best product possible. The most current version of this document will always be available at: www.chromeled.com

SOLDERING CONDITIONS

RECOMMENDED Sn-PB IR-Reflow Soldering Profile

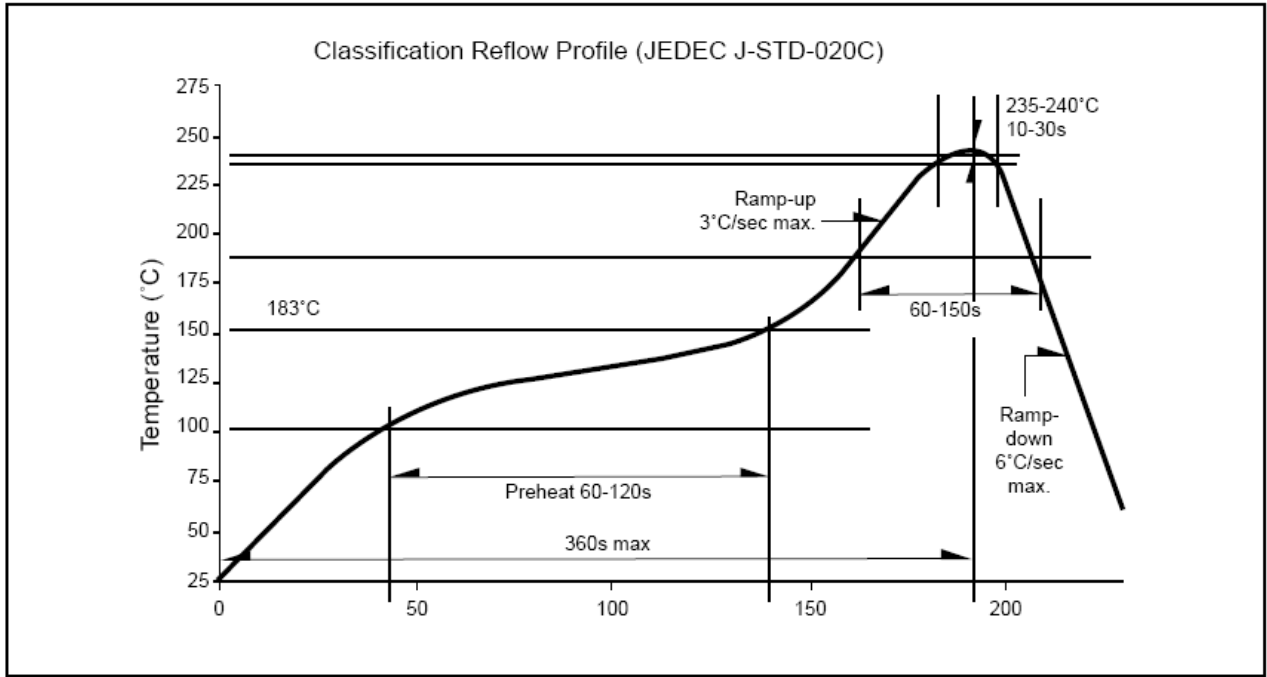

RECOMMENDED Pb-Free Soldering Profile

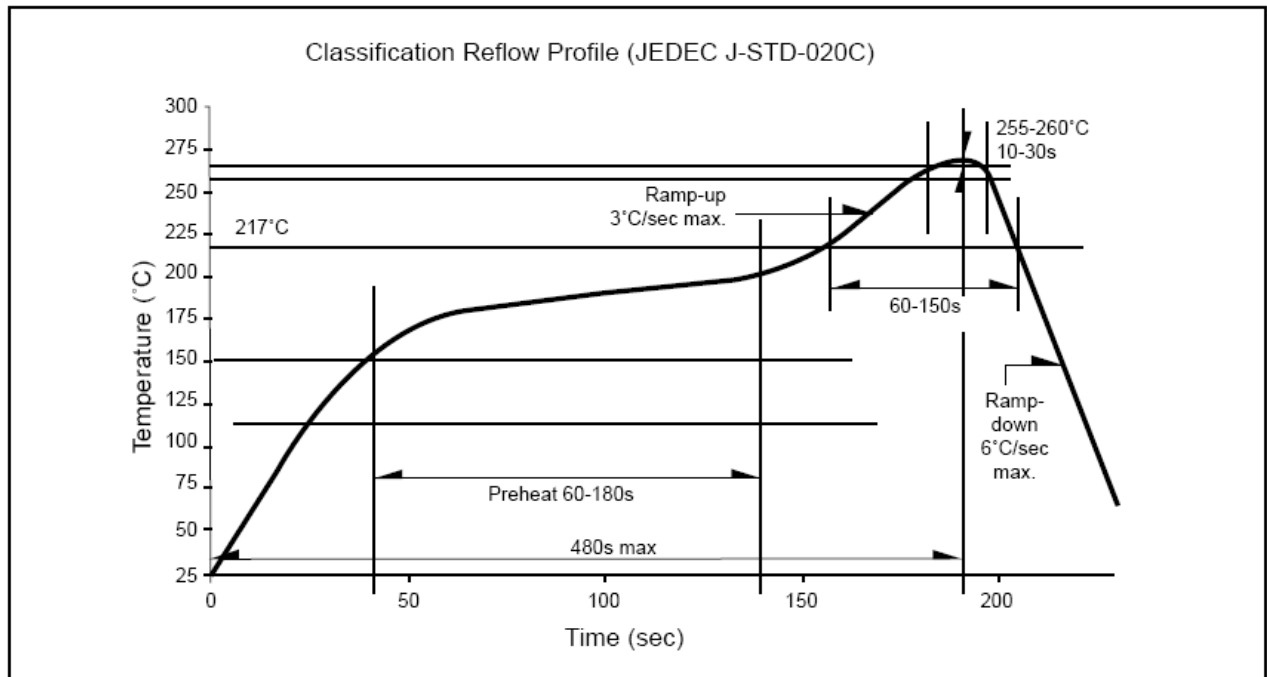

ChromeLED Corp. reserves the right to make changes at any time in order to supply the best product possible. The most current version of this document will always be available at: www.chromeled.com