

SPECIFICATIONS **CL50IR840C-70**

OUTLINES DIMENSIONS

DESCRIPTION

- Round Type
- 5mm Diameter
- Lens Color: Water Clear
- With Flange
- Solder leads without standoff

FEATURES

- Infrared Emitting Diode
- Technology: AlGaAs
- Peak Wavelength $\lambda_p = 840\text{nm}$ Typ

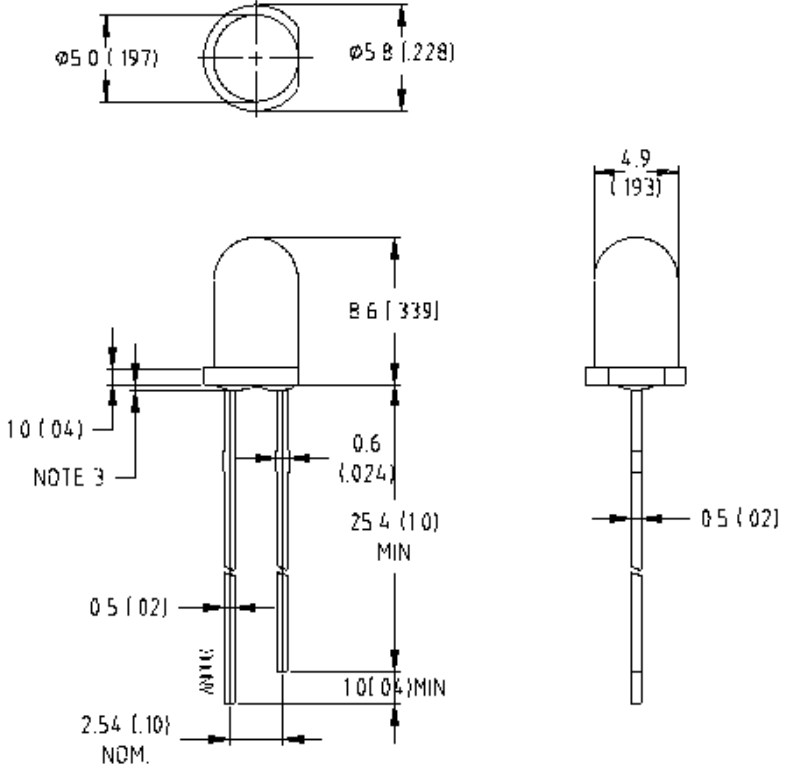

- Notes:
1. All Dimensions are in millimeters (inches).
 2. Tolerance is $\pm 0.25\text{mm}$ (0.01") unless otherwise noted.
 3. Specifications are subject to change without notice.

Part Number	Chip Material	Color of Emission	Lens Type	Viewing Angle
CL50IR840C-70	AlGaAs	Infrared	Water Clear	70°



ChromeLED Corp. reserves the right to make changes at any time in order to supply the best product possible. The most current version of this document will always be available at: www.chromeled.com

ABSOLUTE MAXIMUM RATINGS
(TA=25°C)

Parameter	Symbol	Max Rating	Unit
Power Dissipation	PD	70	mW
Pulse Current Forward Current	IFP	100	mA
Continuous Forward Current	IF	35	mA
Reverse Voltage	VR	5	V
Operating Temperature Range	TOPR	-30~+80	°C
Storage Temperature Range	TSTG	-40~+100	°C
IFP = Pulse Width ≤ 10 ms, Duty Ratio ≤1/10. Soldering Condition: 280 °C/ 5sec			

OPTICAL-ELECTRICAL CHARACTERISTICS
(TA=25°C)

Parameter	Symbol	Test Condition	Value			Unit
			Min	Typ	Max	
Radiant Intensity	IE	IF = 20mA	-	4	-	mW/ Sr
Forward Voltage	VF	IF = 20mA	-	1.4	2.0	V
Reverse Leakage Current	IR	VR = 5V	-	-	10	µA
Viewing Angle	2θ1/2	IF = 20mA	-	70	-	deg
Peak Wavelength	λP	IF = 20mA	835	840	845	nm

*Tolerance of viewing angle: -10 / +5 deg.



ChromeLED Corp. reserves the right to make changes at any time in order to supply the best product possible. The most current version of this document will always be available at: www.chromeled.com

OPTICAL CHARACTERISTIC CURVES

Spectral Radiance (Peak @ 840nm)

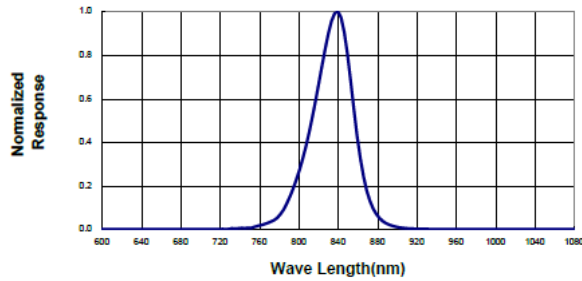

Forward Current vs Forward Voltage

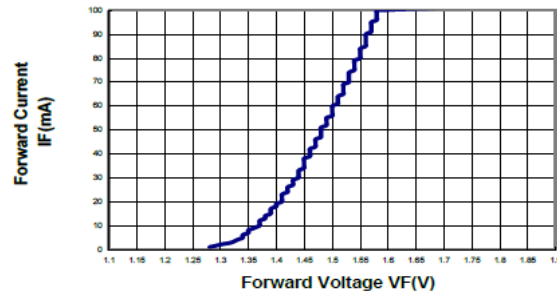

Relative Luminous Intensity vs Forward Current

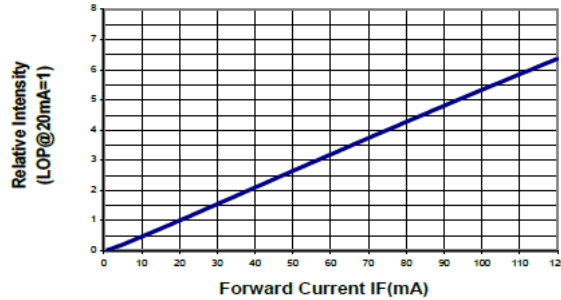

Beam Pattern

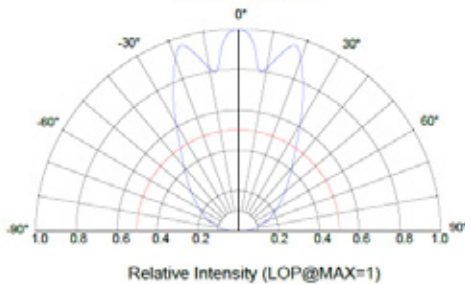

Forward Current Derating Curve

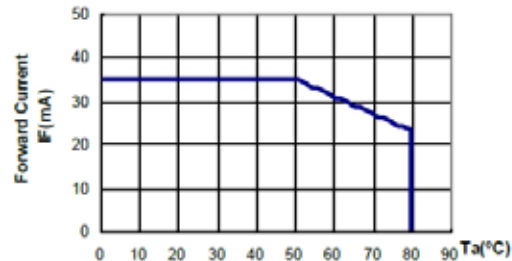

ChromeLED Corp. reserves the right to make changes at any time in order to supply the best product possible. The most current version of this document will always be available at: www.chromeled.com